

MERCEDES - BENZ

/8

/8 (W114)
/8 (W115)

01/1968 - 01/1977



17MR1550

◀ 5



17MR1530

4 ▶



21MR1560

◀ 6



21MR1560

6 ▶



22MR1570

7 ▶



10MR1515

◀ 1



10MR1516

◀ 2



10MR1516

▶



10MR1515

1 ▶



10MR1555

◀ 3



10MR1555

3 ▶



26MR2300

◀ 8 ▶



26MR2300

NO	ASMETAL CODE	DESCRIPTION	MEASURES	OEM
1	10MR1515	Ball Joint Upper	th:M12x1.25 RHT cp:1/10 cs:Ø14,35	115 333 05 27
2	10MR1516	Ball Joint Upper	th:M12x1.25 RHT cp:1/10 cs:Ø14,35	115 333 08 27
3	10MR1555	Ball Joint Lower	th:M14x1.5 RHT cp:1/10 cs:Ø16 do:Ø48,35	115 333 10 27
4	17MR1530	Tie Rod End	c:Ø12,6 th:MM14x1,5 RHT	000 338 07 10
5	17MR1550	Tie Rod End	c:Ø12,6 th:MM14x1,5 LHT	000 338 08 10
6	21MR1560	Tie Rod Adjustable	c:Ø12,6 th:M10x1.0 RHT	016 030 0216
7	22MR1570	Center Rod	th1:M10x1.0 RHT	016 040 6060
8	26MR2300	Stabiliser Link	L:50,75mm Plastic	016 060 0222

MERCEDES - BENZ

100

100 (MB 100) (631)



02 / 1988 - 02 / 1996

Axle no; 733.702 - 705



38MR0500

◀ 10

10 ▶



38MR0500

--> Chas. 013457



17MR0400

◀ 5



17MR0300

◀ 4

▶



17MR0300

5 ▶



17MR0400

3 ▶



17MR0200

--> Chas. 013457



17MR0100

◀ 2



17MR0200

◀ 3

2 ▶



17MR0100

3 ▶



17MR0200

6 ▶



17MR0500



21MR0100

◀ 7

8 ▶



22MR0100

7 ▶



21MR0100

Chas. 013478 -->

9 ▶



22MR0500

1 ▶



10MR1000

1 ▶



10MR1000

NO	ASMETAL CODE	DESCRIPTION	MEASURES	OEM
1	10MR1000	Ball Joint	th:M16x1.5 RHT cp:1/10 cs:Ø20,3 do:Ø26	000 320 00 28
2	17MR0100	Tie Rod End Left	c:Ø18,2 th:MM20x1,5 LHT	631 330 04 35
3	17MR0200	Tie Rod End Right	c:Ø18,2 th:MM20x1,5 RHT	631 338 05 10
4	17MR0300	Tie Rod End Right	c:Ø16,2 th:MM18x1,5 RHT	631 338 04 10
5	17MR0400	Tie Rod End Left	c:Ø16,2 th:MM18x1,5 LHT	631 338 03 10
6	17MR0500	Tie Rod End Right	c:Ø19,9 th:MM24x1,5 RHT	631 330 05 35
7	21MR0100	Tie Rod	c:Ø18,2 th:M16x1.5 RHT	631 330 07 03
8	22MR0100	Tie Rod Center	th1:M18x1.5 RHT L:650,5mm	631 330 06 03
9	22MR0500	Tie Rod Center	th1:M14x1.5 RHT	631 460 07 05
10	38MR0500	Below ,Driveshaft	di:Ø25	631 330 01 85

MERCEDES - BENZ

C123 , W123 , T123, S123

C123 , W123 , T123
 KOMBI Break (S123)
 KOMBI T-Model (S123)

01/1976 - 12/1985
 09/1977 - 12/1985
 09/1977 - 12/1985



--> 08 / 1982



17MR2351



17MR2332

◀ 6 ▶



17MR2332

7 ▶



17MR2351

08 / 1982 -->



17MR1550



17MR1530

◀ 3 ▶



17MR1530

4 ▶



17MR1550



17MR2330

◀ 5 ▶



17MR2330



10MR2355



10MR5000

◀ 2 ▶



10MR5000

1 ▶



10MR2355



26MR2300

◀ 10 ▶



26MR2300

NO	ASMETAL CODE	DESCRIPTION	MEASURES	OEM
1	10MR2355	Ball Joint Lower	th:M14x1.5 RHT cp:1/10 cs:Ø18,3 do:Ø45,4	116 333 09 27
2	10MR5000	Ball Joint Chassis	th:M16x1.5 RHT c:Ø18	123 330 13 35
3	17MR1530	Tie Rod End	c:Ø12,6 th:MM14x1,5 RHT	000 338 52 10
4	17MR1550	Tie Rod End	c:Ø12,6 th:MM14x1,5 LHT	000 338 50 10
5	17MR2330	Tie Rod End	c:Ø12,6 th:MM14x1,5 RHT	000 338 54 10
6	17MR2332	Tie Rod End	c:Ø12,6 th:MM16x1,5 RHT	123 338 01 10
7	17MR2351	Tie Rod End	c:Ø12,6 th:MM16x1,5 LHT	123 338 02 10
8	21MR2360	Rod Assembly	c:Ø12,6 th:M10x1.0 RHT	123 330 18 03
9	22MR2370	Tie Rod Center	th1:M10x1.0 RHT L:476mm	123 460 15 05
10	26MR2300	Stabiliser Link	L:50,75mm Plastic	115 320 15 89

MERCEDES - BENZ

190

190 (W201)



11 / 1982 - 08 / 1993

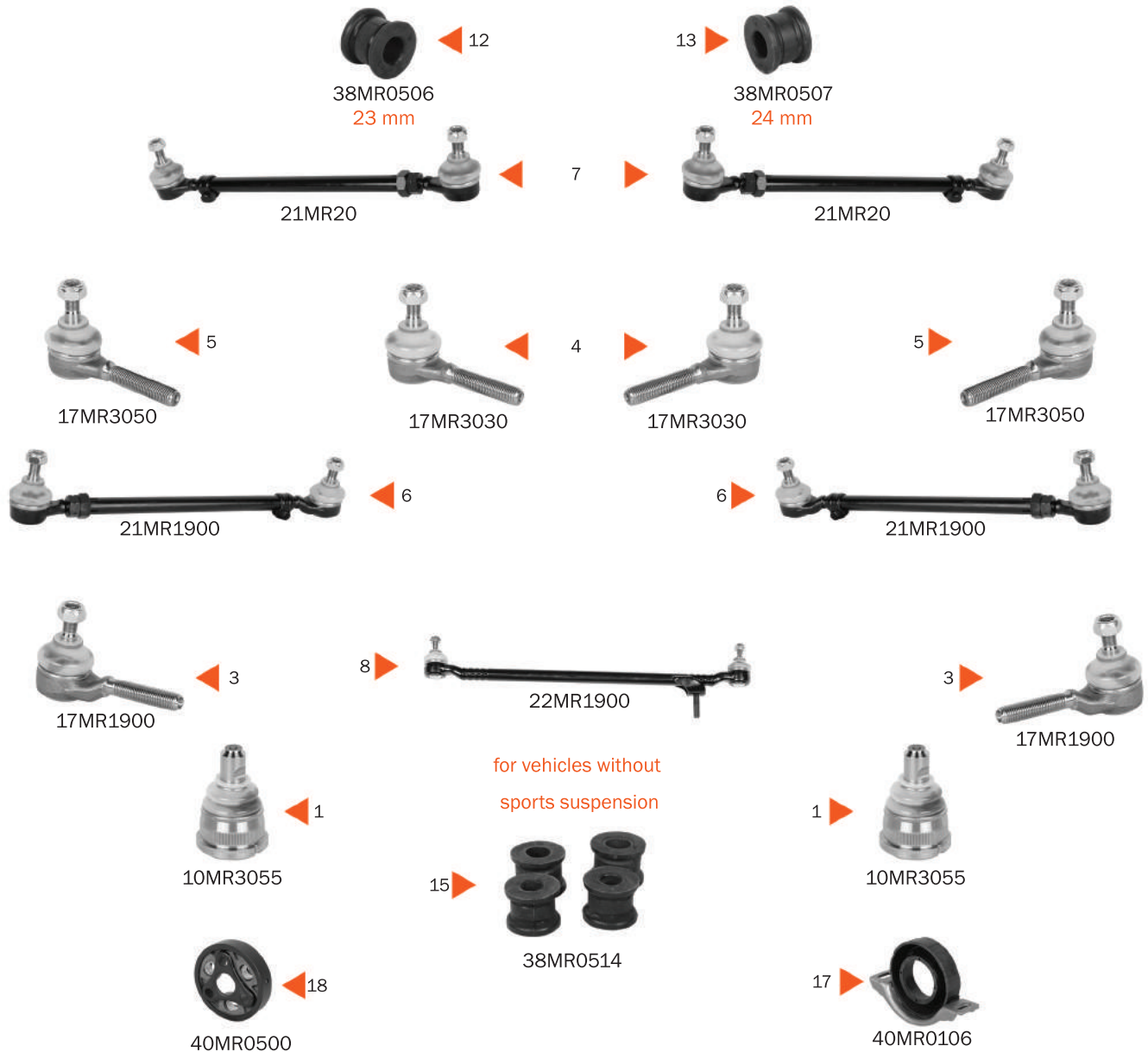

NO	ASMETAL CODE	DESCRIPTION	MEASURES	OEM
1	10MR3055	Ball Joint	c:Ø18 do:Ø46,4	124 333 03 27
3	17MR1900	Tie Rod End	c:Ø10,7 th:MM12x1,5 RHT	000 338 63 10
4	17MR3030	Tie Rod End Inner	c:Ø10,7 th:MM12x1,5 RHT	000 338 42 10
5	17MR3050	Tie Rod End Outer	c:Ø10,7 th:MM12x1,5 LHT	000 338 62 10
6	21MR1900	Tie Rod	c:Ø10,7 th:M10x1.0 RHT	201 330 16 03
7	21MR20	Tie Rod	c:Ø10,7 th:M10x1.0 RHT	201 330 15 03
8	22MR1900	Tie Rod Center	th1:M10x1.0 RHT L:490mm	201 460 15 05
12	38MR0506	Stabiliser Mounting	di:Ø22 do:Ø39,5	124 323 49 85
13	38MR0507	Stabiliser Mounting	di:Ø24 do:Ø44,5	124 323 17 85
15	38MR0514	Mounting Kit		124 320 00 47
17	40MR0106	Driveshaft		201 410 05 81
18	40MR0500	Driveshaft		202 411 14 47

MERCEDES - BENZ

190

190 (W201)



11 / 1982 - 08 / 1993



NO	ASMETAL CODE	DESCRIPTION	MEASURES	OEM
2	11MR00	Silentblock Bushing	di:Ø14 do:Ø40	204 352 00 27
9	23MR02	Stabiliser Link Rear	c:1:6 th:M10x1.25 RHT L:245mm	210 350 21 53
10	26MR1000	Stabiliser Link Rear	L:197,4mm Plastic	124 320 02 89
11	38MR0502	Silenblock for TCA	di:Ø22	201 350 00 37
14	38MR0509	Silenblock for TCA	di:Ø12,2 do:Ø36	124 352 34 65
16	38MR0515	Silenblock for TCA	di:Ø10,3	124 320 20 31*
19	526MR3110	Bend Clamp		201 323 55 40
20	526MR3111	Bend Clamp		201 323 56 40
21	99MR20	Bearing Journal		601 050 02 16

MERCEDES - BENZ

A - CLASS

A - CLASS (W168)



06 / 1997 - 08 / 2004

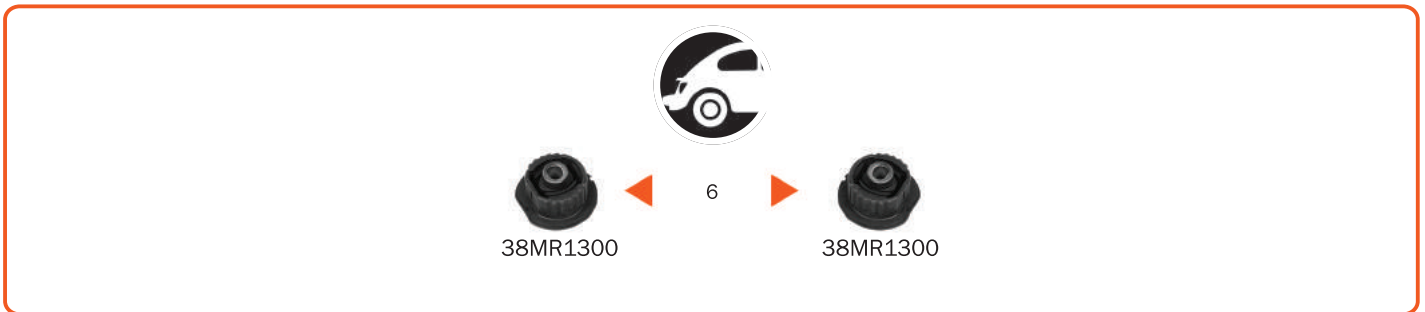
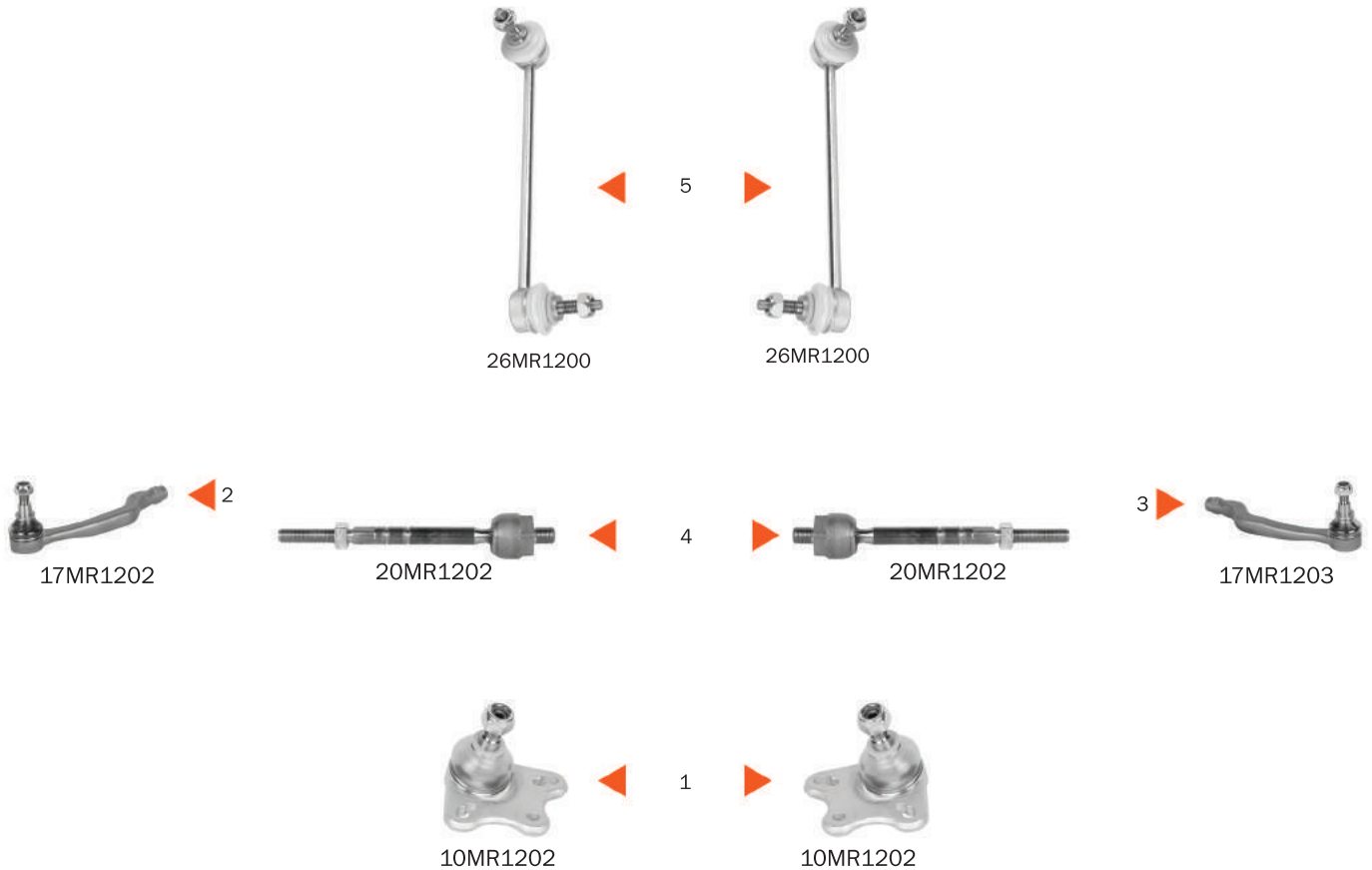

NO	ASMETAL CODE	DESCRIPTION	MEASURES	
1	10MR1202	Ball Joint	th:M12x1.5 RHT cp:1/6 cs:Ø13,75	168 333 01 27
2	17MR1202	Tie Rod End Left	c:Ø14,6 th:FM12x1,5 RHT	168 330 15 35
3	17MR1203	Tie Rod End Right	c:Ø14,6 th:FM12x1,5 RHT	168 330 16 35
4	20MR1202	Axial Joint	th:MM14x1.5 RHT L:197mm	168 330 13 35
5	26MR1200	Stabiliser Link	di:Ø16,6 do:Ø62,5	168 320 03 89
6	38MR1300	Mounting Axle Body		168 351 01 42

MERCEDES - BENZ

A - CLASS

A - CLASS (W169)



01 / 2004 - 06 / 2012

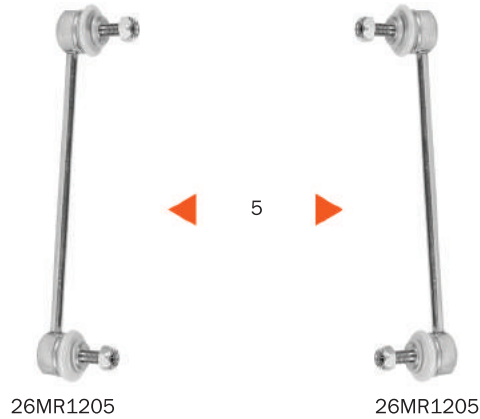

' --> CHAS. J126739
' --> 03 / 2005

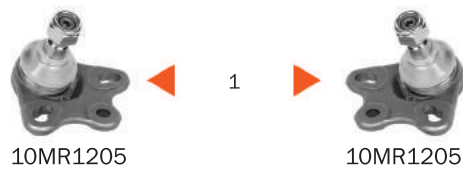
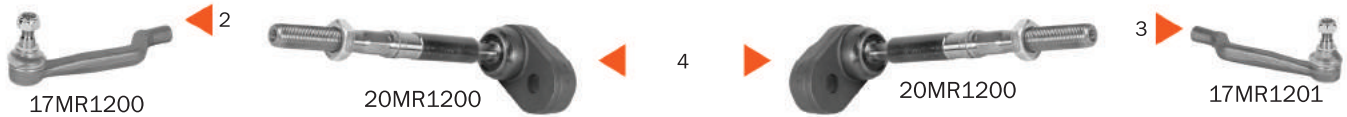

NO	ASMETAL CODE	DESCRIPTION	MEASURES	OEM
1	10MR1205	Ball Joint	th:M14x1.5 RHT cp:1/6 cs:Ø13,4	169 333 01 27
2	17MR1200	Tie Rod End Left	c:Ø16,6 th:FM14x1,5 RHT	169 330 05 03
3	17MR1201	Tie Rod End Right	c:Ø16,6 th:FM14x1,5 RHT	169 330 06 03
4	20MR1200	Axial Joint	L:203mm	169 330 04 03
5	26MR1205	Stabiliser Link	L:244mm	169 320 09 89
6	26MR1210	Stabiliser Link Rear		169 320 05 89

MERCEDES - BENZ

B - CLASS

B - CLASS (W245)



03/2005 - 11/2011

-> 01/2007

-> 01/2007



4

26MR1205

26MR1205



17MR1200



17MR1201



1

10MR1205

10MR1205



26MR1210



26MR1210



NO	ASMETAL CODE	DESCRIPTION	MEASURES	OEM
1	10MR1205	Ball Joint	th:M14x1.5 RHT cp:1/6 cs:Ø13,4	169 333 01 27
2	17MR1200	Tie Rod End Left	c:Ø16,6 th:FM14x1,5 RHT	169 330 05 03
3	17MR1201	Tie Rod End Right	c:Ø16,6 th:FM14x1,5 RHT	169 330 06 03
4	26MR1205	Stabiliser Link	L:244mm	169 320 09 89
5	26MR1210	Stabiliser Link Rear		169 320 05 89

MERCEDES - BENZ

C-CLASS

C-CLASS (W202)
C-CLASS (S202)



03 / 1993 - 05 / 2000
06 / 1996 - 03 / 2001

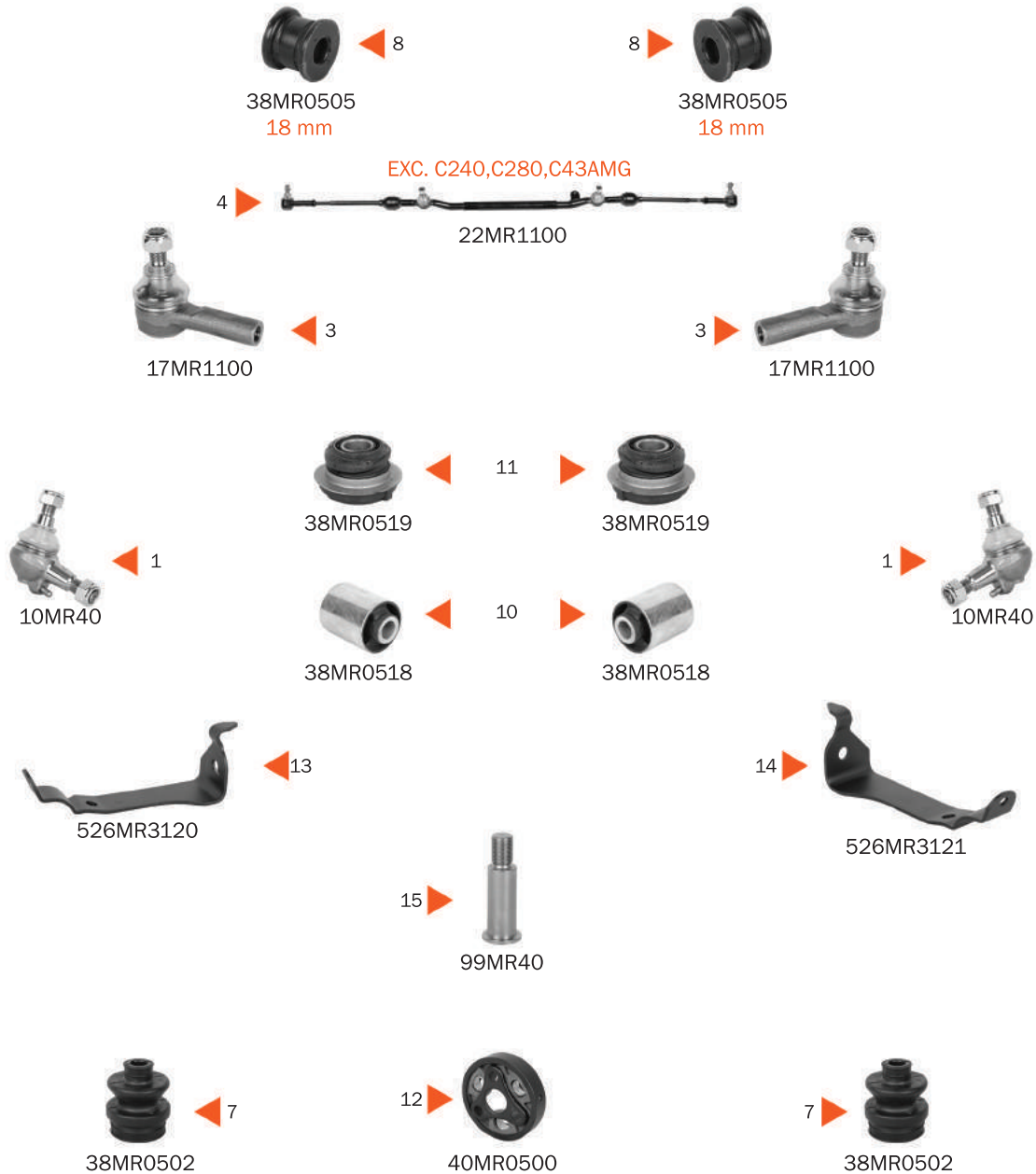

NO	ASMETAL CODE	DESCRIPTION	MEASURES	OEM
1	10MR40	Ball Joint	th:M14x1.5 RHT cp:1/6 cs:Ø15,9	211 330 03 35
3	17MR1100	Tie Rod End	c:Ø14,6 th:FM12x1,5 RHT	001 330 77 35
4	22MR1100	Tie Rod	th1:M12x1.5 RHT L:516,5mm	202 460 04 05
7	38MR0502	Bellow Driveshaft	di:Ø22	201 350 00 37
8	38MR0505	Stabiliser Mounting	di:Ø18,5 do:Ø39,5	124 323 23 85
10	38MR0518	Silentblock for TCA	di:Ø14,2 do:Ø60,2	202 333 64 14
11	38MR0519	Silentblock for TCA	di:Ø20	202 333 67 14
12	40MR0500	Shaft Hanger		202 411 14 47
13	526MR3120	Bracket		202 323 08 40
14	526MR3121	Bracket		202 323 09 40
15	99MR40	Bearing Journal		606 202 01 20

MERCEDES - BENZ

C-CLASS

C-CLASS (W202)
C-CLASS (S202)



03 / 1993 - 05 / 2000
06 / 1996 - 03 / 2001

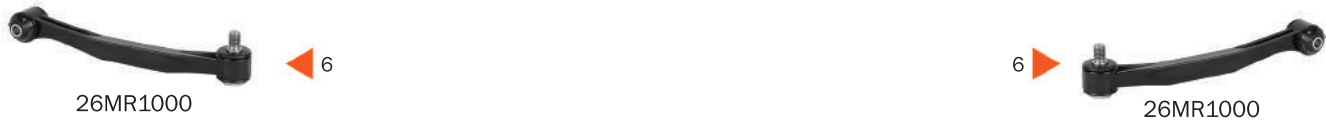
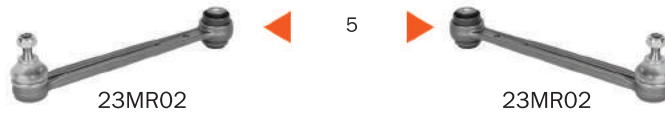
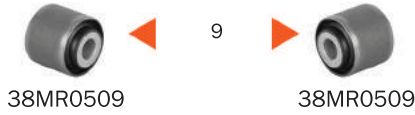

NO	ASMETAL CODE	DESCRIPTION	MEASURES	OEM
2	11MR00	Silentblock Bushing	di:Ø14 do:Ø40	204 352 00 27
5	23MR02	Stabiliser Link Rear	c:1:6 th:M10x1.25 RHT L:245mm	210 350 21 53
6	26MR1000	Stabiliser Link Rear	L:197,4mm Plastic	124 320 02 89
9	38MR0509	Silentblock for TCA	di:Ø12,2 do:Ø36	124 352 34 65

MERCEDES - BENZ

C-CLASS

C-CLASS (W203)
 C-CLASS (S203)
 C-CLASS (CL203)
 CLC (CL203)

05 / 2000 - 01 / 2007
 03 / 2001 - 07 / 2007
 03 / 2001 - 05 / 2008
 05/2008 - 06/2011

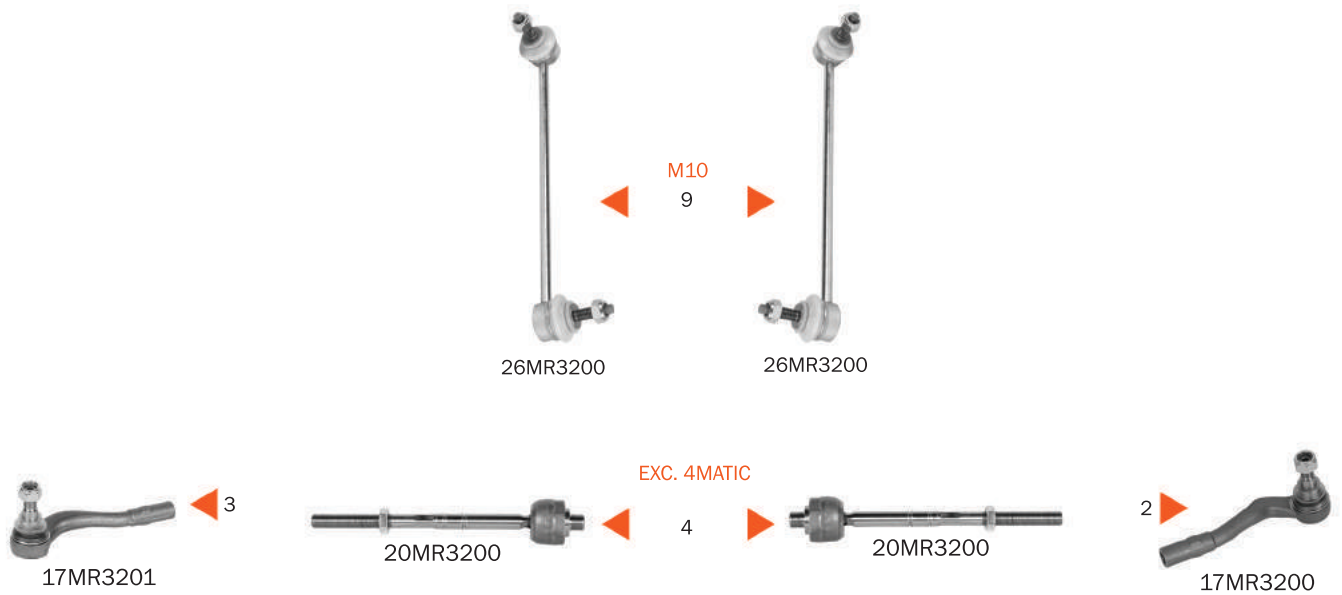

EXC. 4MATIC

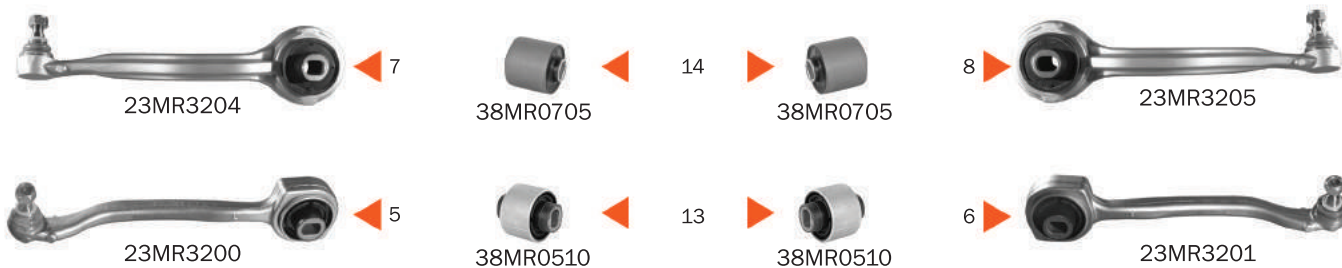

NO	ASMETAL CODE	DESCRIPTION	MEASURES	OEM
2	17MR3200	Tie Rod End Right	c:Ø16 th:FM14x1,5 RHT	203 330 40 03
3	17MR3201	Tie Rod End Left	c:Ø16 th:FM14x1,5 RHT	203 330 39 03
4	20MR3200	Axial Joint	th:MM16x1,5 RHT L:241,5mm	230 338 00 15
5	23MR3200	TCA Lower Left		203 330 19 11
6	23MR3201	TCA Lower Right		203 330 20 11
7	23MR3204	TCA Upper Left		203 330 01 11
8	23MR3205	TCA Upper Right		203 330 02 11
9	26MR3200	Stabiliser Link	L:276mm	203 320 28 89
13	38MR0510	Silentblock for TCA	do:Ø70,6	203 333 03 14
14	38MR0705	Silentblock for TCA	di:Ø24 do:Ø44,5	203 333 02 14

MERCEDES - BENZ

C-CLASS

C-CLASS (W203)
 C-CLASS (S203)
 C-CLASS (CL203)
 CLC (CL203)

05 / 2000 - 01 / 2007
 03 / 2001 - 07 / 2007
 03 / 2001 - 05 / 2008
 05/2008 - 06/2011

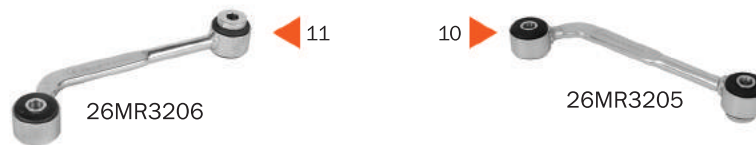
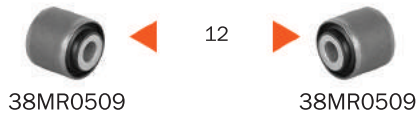

NO	ASMETAL CODE	DESCRIPTION	MEASURES	OEM
1	11MR00	Silentblock Bushing	di:Ø14 do:Ø40	204 352 00 27
10	26MR3205	Stabiliser Link Rear Right	L:185mm	203 320 08 89
11	26MR3206	Stabiliser Link Rear Left	L:185mm	203 320 07 89
12	38MR0509	Silentblock for TCA	di:Ø12,2 do:Ø36	124 352 34 65

MERCEDES - BENZ

C-CLASS

C-CLASS (W204)

C-CLASS (S204)

C-CLASS (C204)

01/2007 - 01/2014

08/2007 - 08/2014

06/2011 - 10/2015



**EXC. SPORT SUSP.
EXC. 4MATIC**

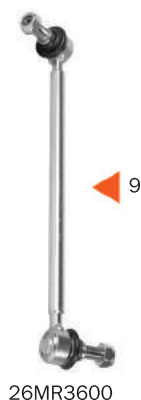

26MR3600

9



26MR3601

10

**HYDRO. PS
EXC. 4MATIC**



20MR3600

2



20MR3600

EXC. 4MATIC + EXC. AMG



23MR3204

3

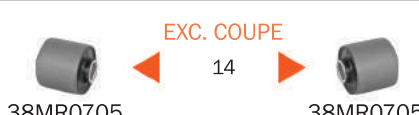

38MR0705

EXC. COUPE

14



23MR3205

4



23MR3210

5

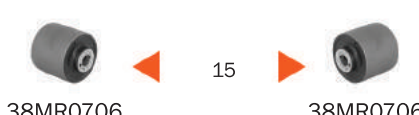

38MR0706

15



23MR3211

6



23MR3214

7



38MR3214

16



23MR3215

8

NO	ASMETAL CODE	DESCRIPTION	MEASURES	OEM
2	20MR3600	Axial Joint	th:MM16x1,5 RHT L:261,5mm	204 338 00 15
3	23MR3204	TCA Upper Left		203 330 01 11
4	23MR3205	TCA Upper Right		203 330 02 11
5	23MR3210	TCA Upper Left		204 330 43 11
6	23MR3211	TCA Upper Right		204 330 44 11
7	23MR3214	TCA Lower Left		204 330 31 11
8	23MR3215	TCA Lower Right		204 330 32 11
9	26MR3600	Stabiliser Link Left	L:306mm	204 320 37 89
10	26MR3601	Stabiliser Link Right	L:306mm	204 320 38 89
14	38MR0705	Silentblock for TCA	di:Ø24 do:Ø44,5	203 333 02 14
15	38MR0706	Silentblock for TCA	di:Ø15 do:Ø70,5	204 333 11 14
16	38MR3214	Silentblock for TCA		204 333 04 14

MERCEDES - BENZ

C-CLASS

C-CLASS (W204)

C-CLASS (S204)

C-CLASS (C204)



01/2007 - 01/2014

08/2007 - 08/2014

06/2011 - 10/2015

SPORT EDITION + AMG



38MR0512

38MR0512

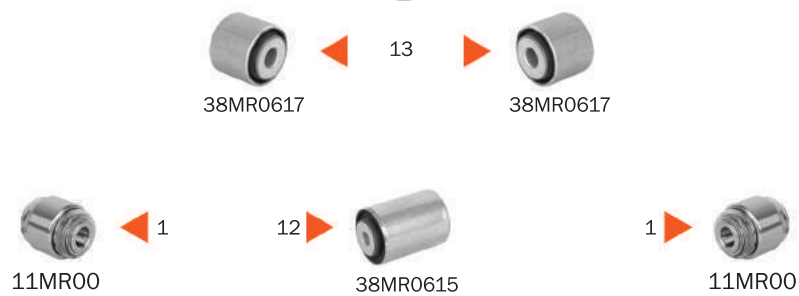

11MR00

38MR0617

38MR0617

38MR0615

11MR00

NO	ASMETAL CODE	DESCRIPTION	MEASURES	OEM
1	11MR00	Silentblock Bushing	di:Ø14 do:Ø40	204 352 00 27
11	38MR0512	Silentblock for TCA	do:Ø70,6	211 333 11 14
12	38MR0615	Silentblock for TCA	di:Ø12,2 do:Ø51,2	222 352 08 65
13	38MR0617	Silentblock for TCA	di:Ø12,2 do:Ø38,5	230 352 15 65

MERCEDES - BENZ

C-CLASS

C-CLASS (W205)

02/2014 ->

C-CLASS (S205)

09/2014 ->

C-CLASS COUPE (C205)

10/2015 ->

C-CLASS CABRIOLET (A205)

06/2016 ->



NO	ASMETAL CODE	DESCRIPTION	MEASURES	OEM
1	11MR00	Silentblock Bushing	di:Ø14 do:Ø40	204 352 00 27
2	38MR0615	Silentblock for TCA	di:Ø12,2 do:Ø51,2	222 352 08 65
3	38MR0617	Silentblock for TCA	di:Ø12,2 do:Ø38,5	230 352 15 65

MERCEDES - BENZ

CITAN

CITAN (W415)



11/2012 ->

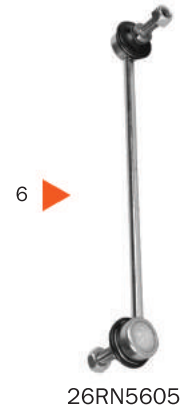
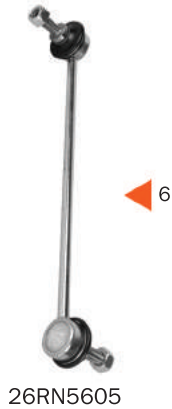

NO	ASMETAL CODE	DESCRIPTION	MEASURES	OEM
1	10RN5605	Ball Joint Right	c:Ø20	82 00 586 567
2	10RN5606	Ball Joint Left	c:Ø20	82 00 586 561
3	17RN5605	Tie Rod End Right	c:Ø11,8 th:FM14x1,5 RHT	77 01 478 408
4	17RN5606	Tie Rod End Left	c:Ø11,8 th:FM14x1,5 RHT	77 01 478 407
5	20RN5605	Axial Joint	th:MM14x1,5 RHT L:214,5mm	77 01 478 406
6	26RN5605	Stabiliser Link	L:283mm	82 00 669 065
7	30RN5606	TCA Left		415 330 03 00
8	30RN5607	TCA Right		415 330 02 00
9	38RN5541	Silentblock for TCA	di:Ø12 do:Ø33,1	82 00 242 025
10	38RN5542	Silentblock for TCA	di:Ø12,2 do:Ø58	82 00 041 166

MERCEDES - BENZ

CLK - CLASS

CLK - CLASS (C208)
CLK - CLASS (A208)

06 / 1997 - 06 / 2002
06 / 1997 - 06 / 2002

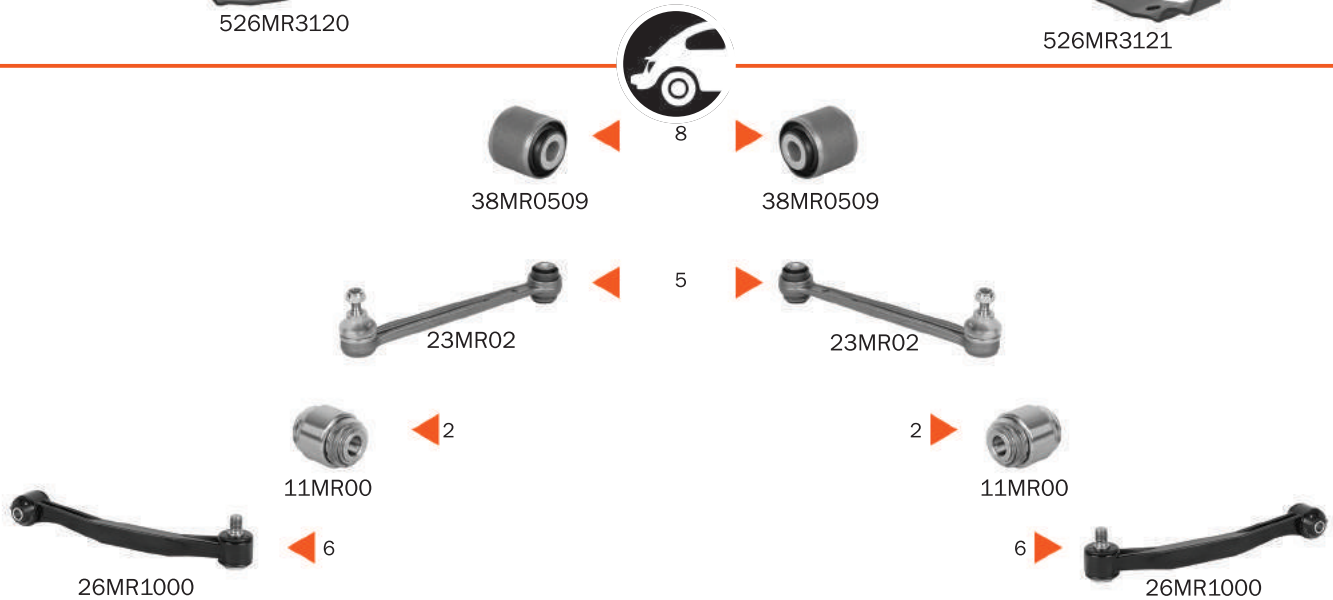

NO	ASMETAL CODE	DESCRIPTION	MEASURES	OEM
1	10MR40	Ball Joint	th:M14x1.5 RHT cp:1/6 cs:Ø15,9	211 330 03 35
2	11MR00	Silentblock Bushing	di:Ø14 do:Ø40	204 352 00 27
3	17MR1100	Tie Rod End	c:Ø14,6 th:FM12x1,5 RHT	001 330 77 35
4	22MR1100	Tie Rod	th1:M12x1.5 RHT L:516,5mm	202 460 04 05
5	23MR02	Stabiliser Link Rear	c:1:6 th:M10x1.25 RHT L:245mm	210 350 21 53
6	26MR1000	Stabiliser Link Rear	L:197,4mm Plastic	124 320 02 89
7	38MR0505	Stabiliser Mounting	di:Ø18,5 do:Ø39,5	124 323 23 85
8	38MR0509	Silentblock for TCA	di:Ø12,2 do:Ø36	124 352 34 65
9	38MR0521	Silentblock for TCA	di:Ø15,3 do:Ø60	208 333 01 14
10	526MR3120	Bracket		202 323 08 40
11	526MR3121	Bracket		202 323 09 40

MERCEDES - BENZ

CLK - CLASS

CLK - CLASS (C209)
CLK - CLASS (A209)



06 / 2002 - 05 / 2009
02 / 2003 - 03 / 2010

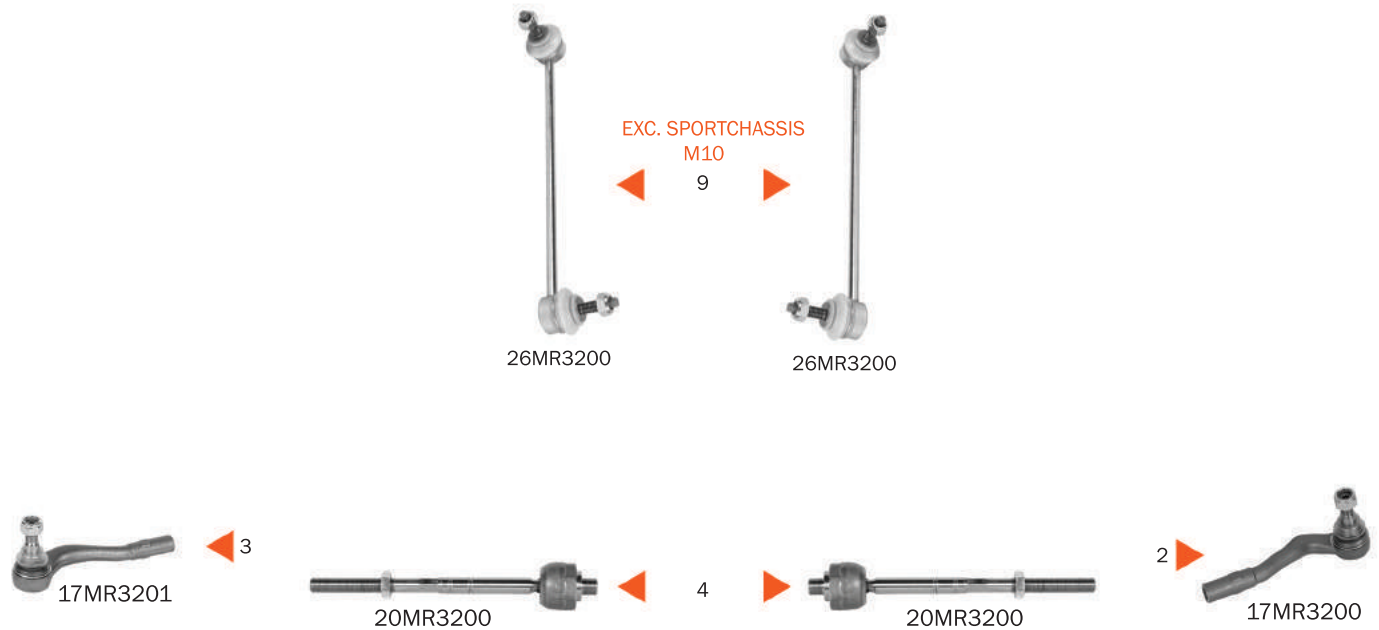

EXC. 4MATIC

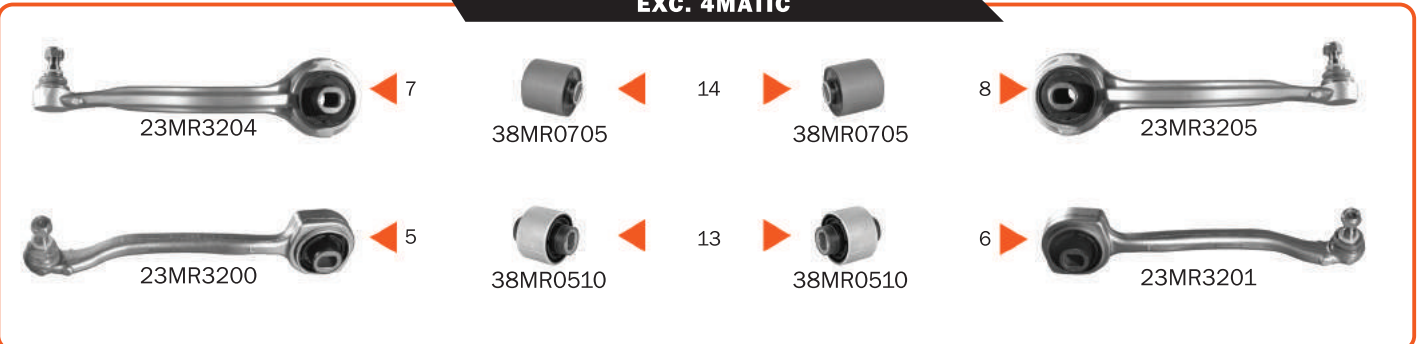

NO	ASMETAL CODE	DESCRIPTION	MEASURES	OEM
2	17MR3200	Tie Rod End Right	c:Ø16 th:FM14x1,5 RHT	203 330 40 03
3	17MR3201	Tie Rod End Left	c:Ø16 th:FM14x1,5 RHT	203 330 39 03
4	20MR3200	Axial Joint	th:MM16x1,5 RHT L:241,5mm	230 338 00 15
5	23MR3200	TCA Lower Left		203 330 19 11
6	23MR3201	TCA Lower Right		203 330 20 11
7	23MR3204	TCA Upper Left		203 330 01 11
8	23MR3205	TCA Upper Right		203 330 02 11
9	26MR3200	Stabiliser Link	L:276mm	203 320 28 89
13	38MR0510	Silentblock for TCA	do:Ø70,6	203 333 03 14
14	38MR0705	Silentblock for TCA	di:Ø24 do:Ø44,5	203 333 02 14

MERCEDES - BENZ

CLK - CLASS

CLK - CLASS (C209)
CLK - CLASS (A209)



06 / 2002 - 05 / 2009
02 / 2003 - 03 / 2010

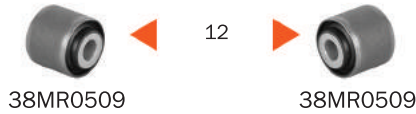

NO	ASMETAL CODE	DESCRIPTION	MEASURES	OEM
1	11MR00	Silentblock Bushing	di:Ø14 do:Ø40	204 352 00 27
10	26MR3205	Stabiliser Link Rear Right	L:185mm	203 320 08 89
11	26MR3206	Stabiliser Link Rear Left	L:185mm	203 320 07 89
12	38MR0509	Silentblock for TCA	di:Ø12,2 do:Ø36	124 352 34 65

MERCEDES - BENZ

CLS - CLASS

CLS - CLASS (C219)



10 / 2004 - 12 / 2012

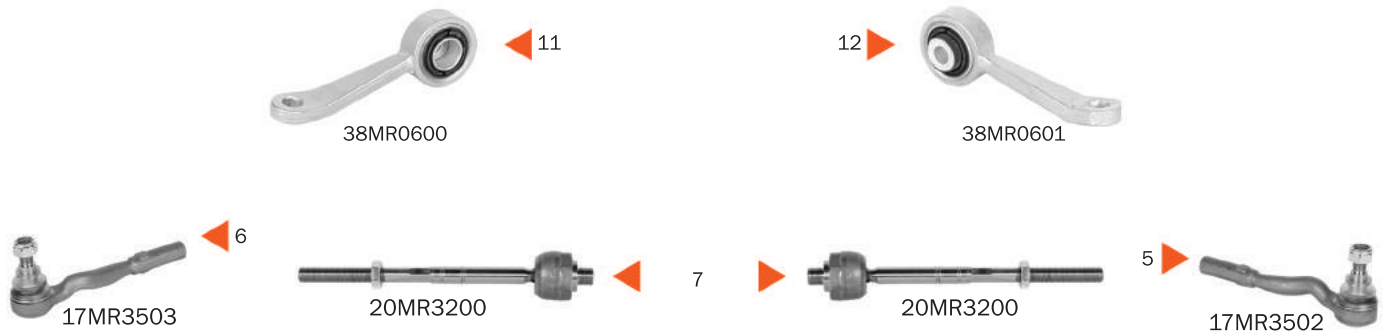

Upper



Lower

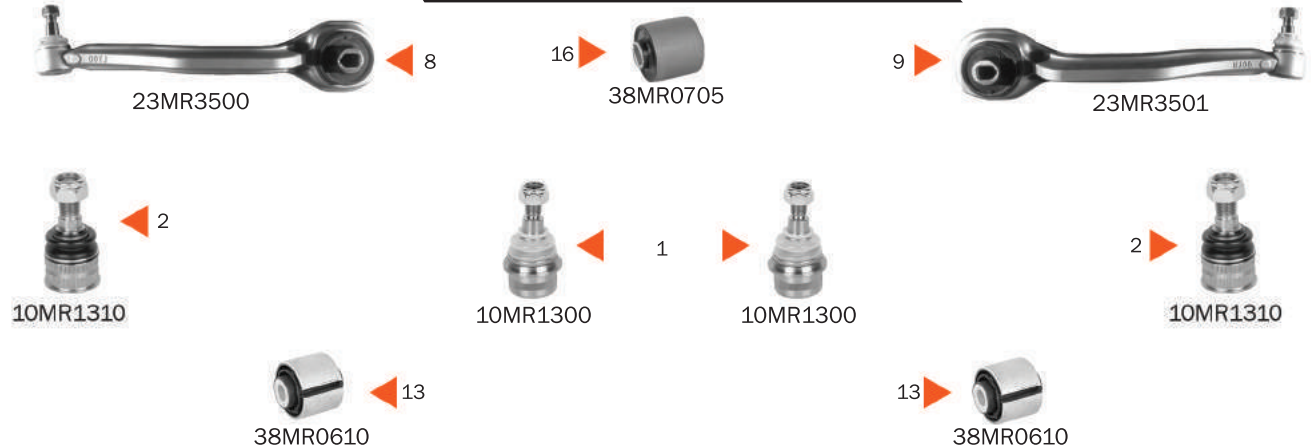

NO	ASMETAL CODE	DESCRIPTION	MEASURES	OEM
1	10MR1300	Ball Joint Lower	th:M14x1.5 RHT cp:1/10 cs:Ø17,1 do:Ø41,25	211 330 99 07
2	10MR1310	Ball Joint Lower	th:M14x1.5 RHT do:Ø34,3	211 323 00 68
3	10MR3502	Ball Joint Upper	th:M10x1.5 RHT cp:1/10 cs:Ø13	230 333 02 27
5	17MR3502	Tie Rod End Right	c:Ø16,6 th:FM14x1,5 RHT	211 330 28 03
6	17MR3503	Tie Rod End Left	c:Ø16,6 th:FM14x1,5 RHT	211 330 27 03
7	20MR3200	Axial Joint	th:MM16x1,5 RHT L:241,5mm	230 338 00 15
8	23MR3500	TCA Left		211 330 43 11
9	23MR3501	TCA Right		211 330 44 11
11	38MR0600	Stabiliser Link Left	di:Ø14,2	211 320 39 89
12	38MR0601	Stabiliser Link Right	di:Ø14,2	211 320 38 89
13	38MR0610	Silentblock for TCA	di:Ø14,2 do:Ø52,5	211 333 19 14
16	38MR0705	Silentblock for TCA	di:Ø24 do:Ø44,5	203 333 02 14

MERCEDES - BENZ

CLS - CLASS

CLS - CLASS (C219)



10 / 2004 - 12 / 2012

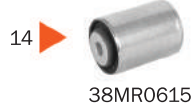
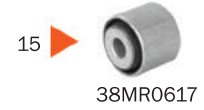

NO	ASMETAL CODE	DESCRIPTION	MEASURES	OEM
4	11MR00	Silentblock Bushing	di:Ø14 do:Ø40	204 352 00 27
10	26MR1300	Stabiliser Link Rear	L:260mm	211 320 33 89
14	38MR0615	Silentblock for TCA	di:Ø12,2 do:Ø51,2	222 352 08 65
15	38MR0617	Silentblock for TCA	di:Ø12,2 do:Ø38,5	230 352 15 65

MERCEDES - BENZ

CLS - CLASS

CLS (C218)
CLS SHOOTING BRAKE (X218)



01/2011 ->
10/2012 ->

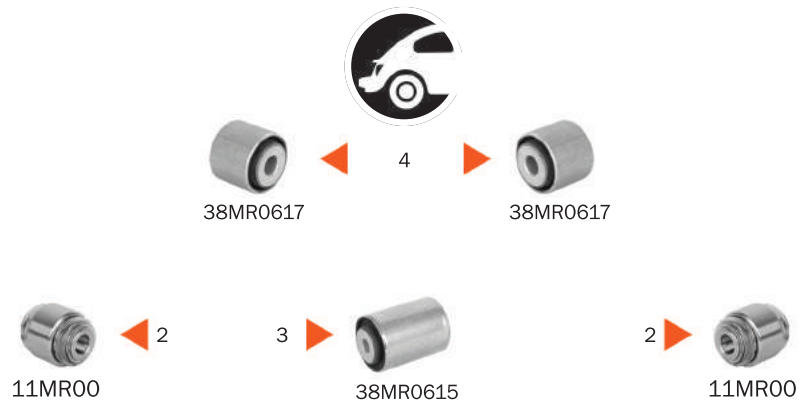

NO	ASMETAL CODE	DESCRIPTION	MEASURES	OEM
1	10MR4010	Ball Joint		212 330 01 35
2	11MR00	Silentblock Bushing	di:Ø14 do:Ø40	204 352 00 27
3	38MR0615	Silentblock for TCA	di:Ø12,2 do:Ø51,2	222 352 08 65
4	38MR0617	Silentblock for TCA	di:Ø12,2 do:Ø38,5	230 352 15 65

MERCEDES - BENZ

E - CLASS

E - CLASS (C124, W124, T124, S124, A124)
EXC. 4 MATIC



12 / 1984 - 06 / 1995



-- > 09 / 1989



09 / 1989 -- >



NO	ASMETAL CODE	DESCRIPTION	MEASURES	OEM
3	17MR1000	Tie Rod End Inner	c:Ø12,6 th:MM14x1,5 LHT	000 338 59 10
4	17MR2330	Tie Rod End Outer	c:Ø12,6 th:MM14x1,5 RHT	000 338 41 10
5	21MR1000	Tie Rod	c:Ø12,6 th:M10x1.0 RHT	124 330 08 03
6	22MR2380	Tie Rod Center	th1:M12x1.5 RHT L:525mm	124 460 12 05
7	22MR2381	Tie Rod Center	th1:M10x1.0 RHT L:535mm	124 460 08 05
11	38MR0505	Stabiliser Mounting	di:Ø18,5 do:Ø39,5	124 323 23 85
12	38MR0506	Stabiliser Mounting	di:Ø22 do:Ø39,5	124 323 23 85
13	38MR0507	Stabiliser Mounting	di:Ø24 do:Ø44,5	124 323 17 85

MERCEDES - BENZ

E - CLASS

E - CLASS (C124, W124, T124, S124, A124)
EXC. 4 MATIC



12 / 1984 - 06 / 1995



◀ 1

10MR3055



1 ▶

10MR3055



◀ 10

38MR0502



10 ▶

38MR0502



◀ 19

526MR3100



20 ▶

526MR3101



◀ 17

40MR0105



18 ▶

40MR0500



21 ▶

99MR40

NO	ASMETAL CODE	DESCRIPTION	MEASURES	OEM
1	10MR3055	Ball Joint	c:Ø18 do:Ø46,4	124 333 03 27
10	38MR0502	Axle Boot	di:Ø22	201 350 00 37
17	40MR0105	Driveshaft Bearing		124 410 01 81
18	40MR0500	Suspension Drive Shaft		124 410 01 81
19	526MR3100	Bend Clamp		124 323 00 26
20	526MR3101	Bend Clamp		124 323 01 26
21	99MR40	Bearing Journal		606 202 01 20

MERCEDES - BENZ

E - CLASS

E - CLASS (C124, W124, T124, S124, A124)
EXC. 4 MATIC



12 / 1984 - 06 / 1995

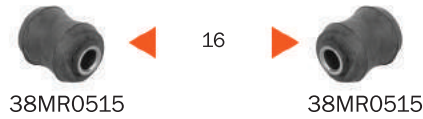

38MR0515

38MR0515

-> Chass. No. A 204766

for vehicles without sports suspension



23MR02



38MR0514



23MR02



11MR00

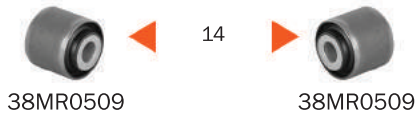

38MR0509

38MR0509



11MR00



26MR1000



26MR1000

NO	ASMETAL CODE	DESCRIPTION	MEASURES	OEM
2	11MR00	Silentblock Bushing	di:Ø14 do:Ø40	204 352 00 27
8	23MR02	Stabiliser Link rear	c:1:6 th:M10x1.25 RHT L:245mm	210 350 21 53
9	26MR1000	Stabiliser Link rear	L:197,4mm Plastic	124 320 02 89
14	38MR0509	Silentblock for TCA	di:Ø12,2 do:Ø36	124 352 34 65
15	38MR0514	Mounting Kit		124 320 00 47
16	38MR0515	Shock Absorber Bushing	di:Ø10,3	124 320 20 31*

MERCEDES - BENZ

E - CLASS

E - CLASS (W 210)
E - CLASS (S 210)



06 / 1995 - 08 / 2003
06 / 1996 - 03 / 2003

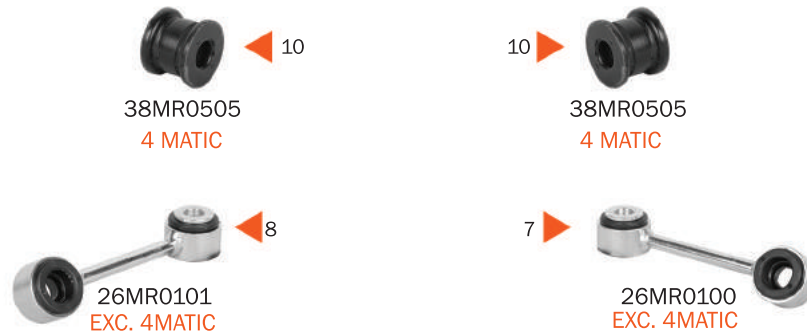

EXC. 4MATIC

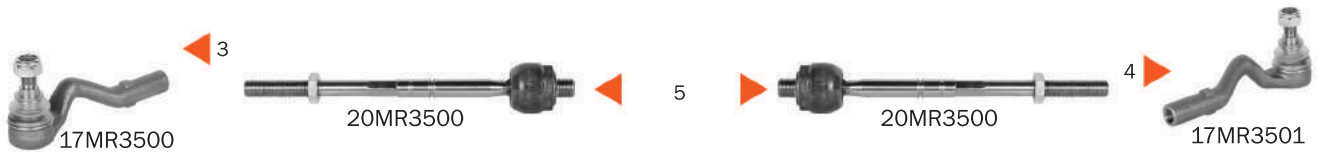

NO	ASMETAL CODE	DESCRIPTION	MEASURES	OEM
1	10MR40	Ball Joint	th:M14x1.5 RHT cp:1/6 cs:Ø15,9	211 330 03 35
3	17MR3500	Tie Rod End Left	c:Ø16,6 th:FM14x1,5 RHT	210 338 05 15
4	17MR3501	Tie Rod End Right	c:Ø16,6 th:FM14x1,5 RHT	210 338 10 15
5	20MR3500	Axial Joint	th:MM16x1,5 RHT L:245,5mm	210 338 04 15
7	26MR0100	Stabiliser Link Right	L:115mm	210 320 37 89
8	26MR0101	Stabiliser Link Left	L:115mm	210 320 36 89
10	38MR0505	Stabiliser Mounting	di:Ø18,5 do:Ø39,5	124 323 23 85
12	38MR0517	Silentblock for TCA	di:Ø20 do:Ø50	210 333 55 14
13	38MR2500	Silentblock for TCA	di:Ø15 do:Ø60	210 333 68 14
14	99MR20	Bearing Journal		601 050 02 16
15	99MR40	Bearing Journal		606 202 01 20

MERCEDES - BENZ

E - CLASS

E - CLASS (W 210)
E - CLASS (S 210)



06 / 1995 - 08 / 2003
06 / 1996 - 03 / 2003

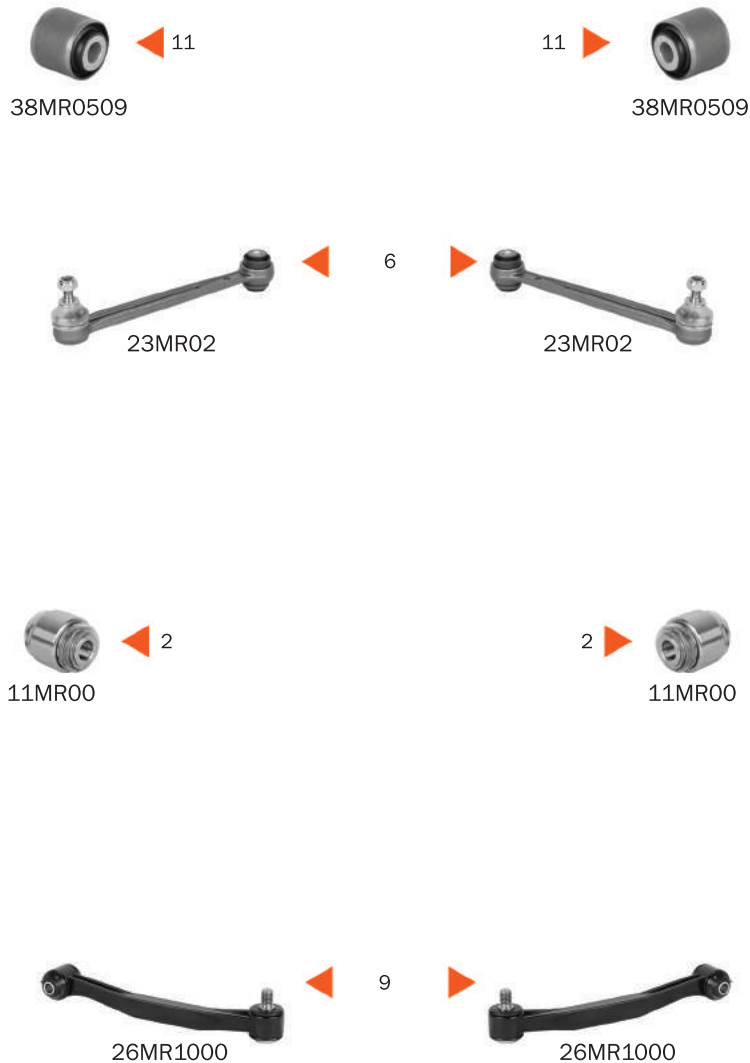

NO	ASMETAL CODE	DESCRIPTION	MEASURES	OEM
2	11MR00	Silentblock Bushing	di:Ø14 do:Ø40	204 352 00 27
6	23MR02	Stabiliser Link Rear	c:1:6 th:M10x1.25 RHT L:245mm	210 350 21 53
9	26MR1000	Stabiliser Link Rear	L:197,4mm Plastic	124 320 02 89
11	38MR0509	Silentblock for TCA	di:Ø12,2 do:Ø36	124 352 34 65

MERCEDES - BENZ

E - CLASS

E - CLASS (W 211, S211)



03 / 2002 - 09 / 2009

EXC. 4MATIC

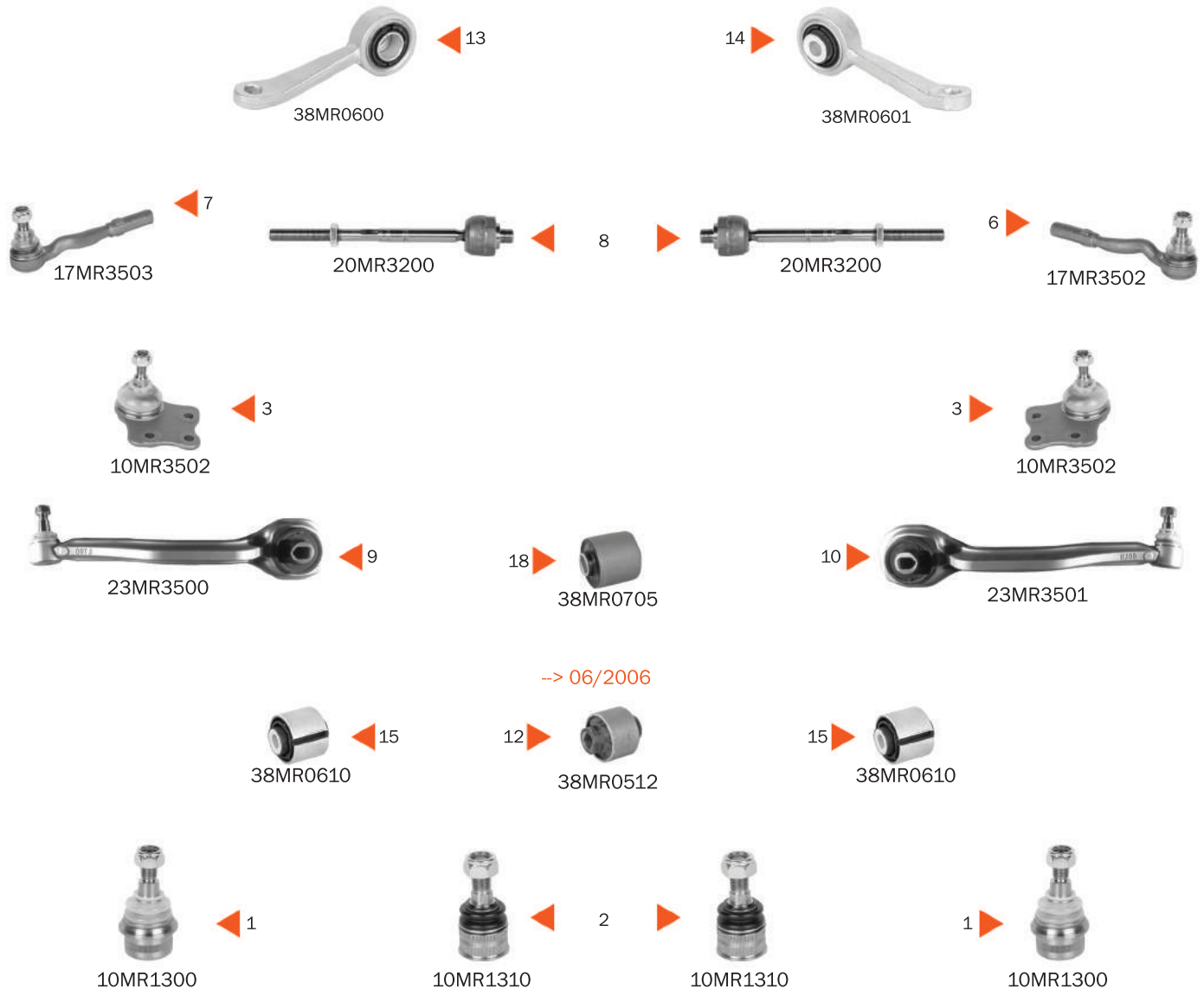

NO	ASMETAL CODE	DESCRIPTION	MEASURES	OEM
1	10MR1300	Ball Joint	th:M14x1.5 RHT cp:1/10 cs:Ø17,1 do:Ø41,25	220 333 07 27
2	10MR1310	Ball Joint	th:M14x1.5 RHT do:Ø34,3	211 323 00 68
3	10MR3502	Ball Joint	th:M10x1.5 RHT cp:1/10 cs:Ø13	211 330 99 07
6	17MR3502	Tie Rod End Right	c:Ø16,6 th:FM14x1,5 RHT	211 330 28 03
7	17MR3503	Tie Rod End Left	c:Ø16,6 th:FM14x1,5 RHT	211 330 27 03
8	20MR3200	Axial Joint	th:MM16x1,5 RHT L:241,5mm	230 338 00 15
9	23MR3500	TCA Left		211 330 43 11
10	23MR3501	TCA Right		211 330 44 11
12	38MR0601	Silentblock for TCA	do:Ø70,6	211 333 11 14
13	38MR0610	Stabiliser Link Left	di:Ø14,2	211 320 39 89
14	38MR0601	Stabiliser Link Right	di:Ø14,2	211 320 38 89
15	38MR0610	Silentblock for TCA	di:Ø14,2 do:Ø52,5	211 333 19 14
18	38MR0705	Silentblock for TCA	di:Ø24 do:Ø44,5	203 333 02 14

MERCEDES - BENZ

E - CLASS

E - CLASS (W 211, S211)



03 / 2002 - 09 / 2009

4MATIC

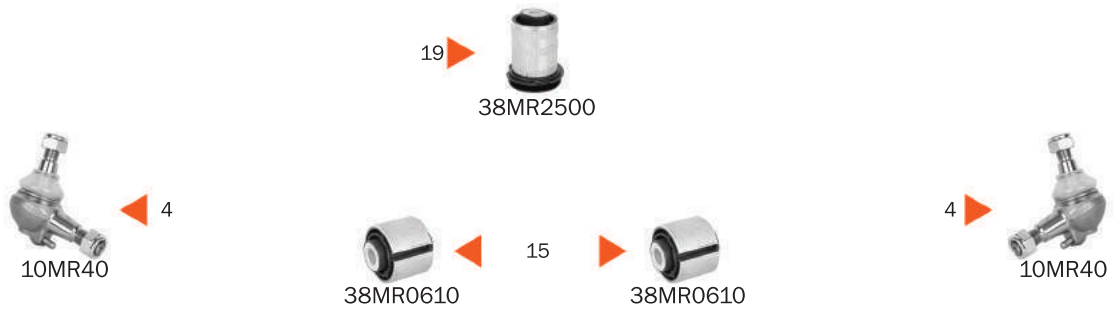

NO	ASMETAL CODE	DESCRIPTION	MEASURES	OEM
4	10MR40	Ball Joint	th:M14x1.5 RHT cp:1/6 cs:Ø15,9	211 330 03 35
5	11MR00	Silentblock Bushing	di:Ø14 do:Ø40	204 352 00 27
11	26MR1300	Stabiliser Link Rear	L:260mm	211 320 33 89
15	38MR0610	Silentblock for TCA	di:Ø14,2 do:Ø52,5	211 333 19 14
16	38MR0615	Silentblock for TCA	di:Ø12,2 do:Ø51,2	222 352 08 65
17	38MR0617	Silentblock for TCA	di:Ø12,2 do:Ø38,5	230 352 15 65
19	38MR2500	Silentblock for TCA	di:Ø15 do:Ø60	210 333 68 14

MERCEDES - BENZ

E - CLASS

E - CLASS (W 212)
E - CLASS (S 212)

01/2009 - 01/2016
08/2009 - 07/2016

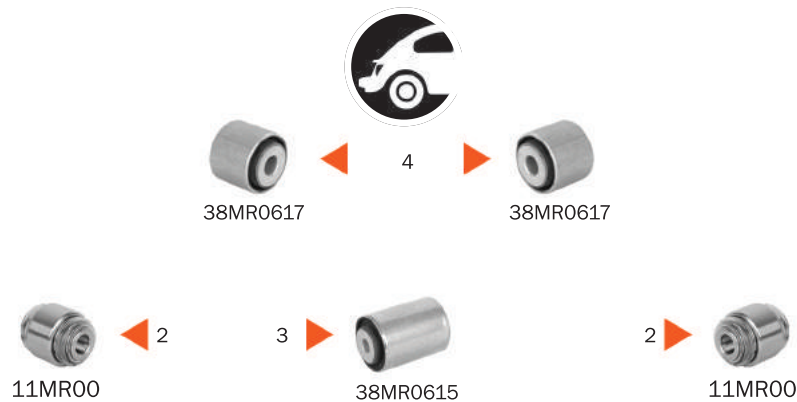

NO	ASMETAL CODE	DESCRIPTION	MEASURES	OEM
1	10MR4010	Ball Joint		212 330 01 35
2	11MR00	Silentblock Bushing	di:Ø14 do:Ø40	204 352 00 27
3	38MR0615	Silentblock for TCA	di:Ø12,2 do:Ø51,2	222 352 08 65
4	38MR0617	Silentblock for TCA	di:Ø12,2 do:Ø38,5	230 352 15 65

E-CLASS (W213)
E-CLASS (S213)



01/2016 ->
07/2016 ->

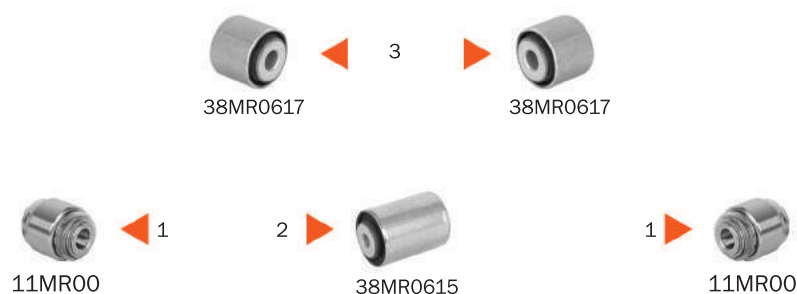

NO	ASMETAL CODE	DESCRIPTION	MEASURES	OEM
1	11MR00	Silentblock Bushing	di:Ø14 do:Ø40	204 352 00 27
2	38MR0615	Silentblock for TCA	di:Ø12,2 do:Ø51,2	222 352 08 65
3	38MR0617	Silentblock for TCA	di:Ø12,2 do:Ø38,5	230 352 15 65

MERCEDES - BENZ

G-CLASS

G-KLASSE (W461)
G-CLASS (W463)



02 / 1990 -- >
09 / 1989 -- >



17MR0100

◀ 1



17MR0200

2 ▶



17MR6050

◀ 4

C-16



17MR6030

3 ▶

NO	ASMETAL CODE	DESCRIPTION	MEASURES	OEM
1	17MR0100	Tie Rod End Left Outer	c:Ø18,2 th:MM20x1,5 LHT	000 460 7348
2	17MR0200	Tie Rod End Right Outer	c:Ø18,2 th:MM20x1,5 RHT	000 460 7248
3	17MR6030	Tie Rod End Right	c:Ø16,3 th:MM22x1,5 RHT	601 330 52 35
4	17MR6050	Tie Rod End Left	c:Ø16,3 th:MM22x1,5 LHT	601 330 53 35

GLC

GLC (X253)
GLC COUPE (C253)



06/2015 ->
06/2016 ->



38MR0617

◀ 3



38MR0617

3 ▶



38MR0615

2 ▶



11MR00

◀ 1



11MR00

1 ▶

NO	ASMETAL CODE	DESCRIPTION	MEASURES	OEM
1	11MR00	Silentblock Bushing	di:Ø14 do:Ø40	204 352 00 27
2	38MR0615	Silentblock for TCA	di:Ø12,2 do:Ø51,2	222 352 08 65
3	38MR0617	Silentblock for TCA	di:Ø12,2 do:Ø38,5	230 352 15 65

MERCEDES - BENZ

GL - CLASS

GL - CLASS (X 164)



09/2006 -- >

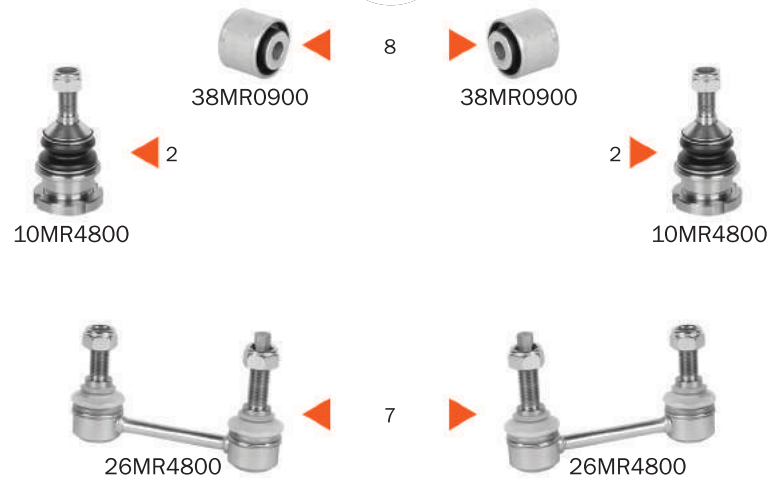
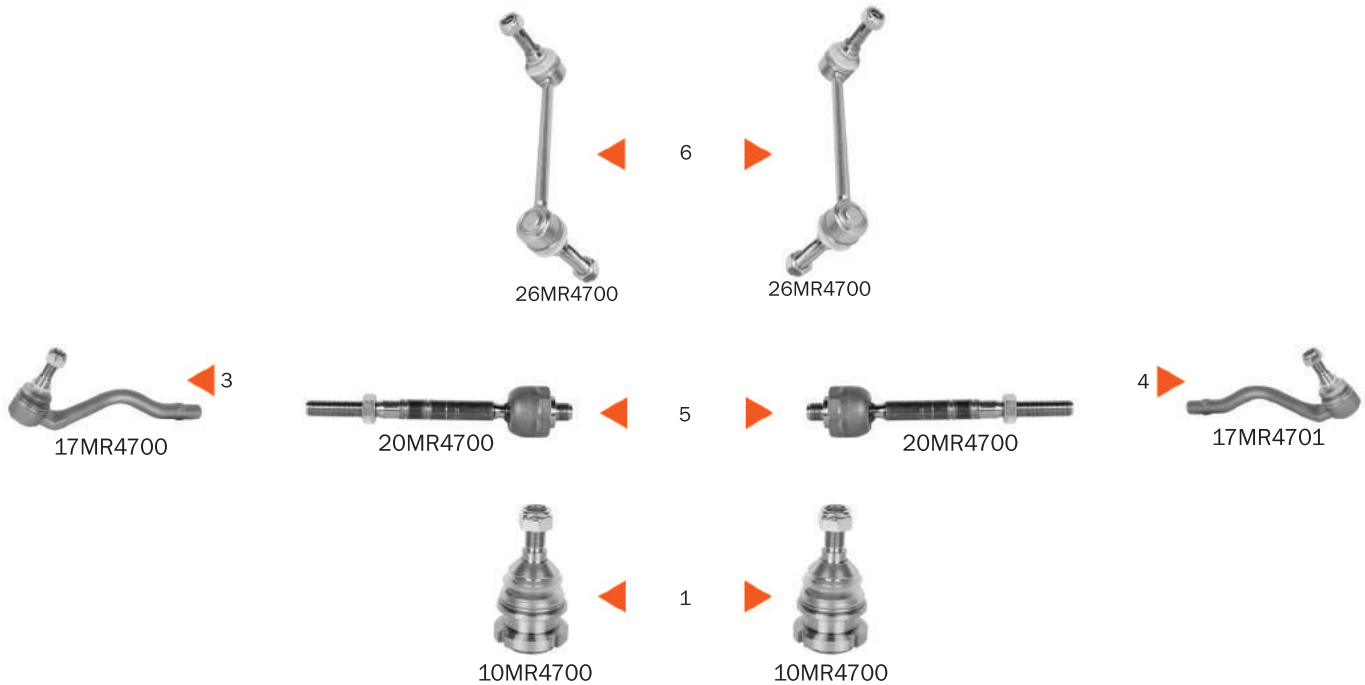

NO	ASMETAL CODE	DESCRIPTION	MEASURES	OEM
1	10MR4700	Ball Joint	th:M16x1.5 RHT th2:M42x1.5 RHT	164 330 09 35
2	10MR4800	Ball Joint	th:M16x1.5 RHT th2:M42x1.5 RHT	164 352 03 27
3	17MR4700	Tie Rod End Left	c:Ø15 th:FM14x1,5 RHT	164 330 11 03
4	17MR4701	Tie Rod End Right	c:Ø15 th:FM14x1,5 RHT / 0,83 kg	164 330 12 03
5	20MR4700	Axial Joint	th:MM16x1,5 RHT L:208,5mm	164 460 00 05
6	26MR4700	Stabiliser Link	L:205mm	164 320 13 32
7	26MR4800	Stabiliser Link Rear	L:117mm	164 320 12 32
8	38MR0900	Silenblock for TCA	di:Ø12,2 do:Ø39,8	164 350 13 06

MERCEDES - BENZ

GL - CLASS

GL - CLASS (X 166)



07 / 2012 -- >

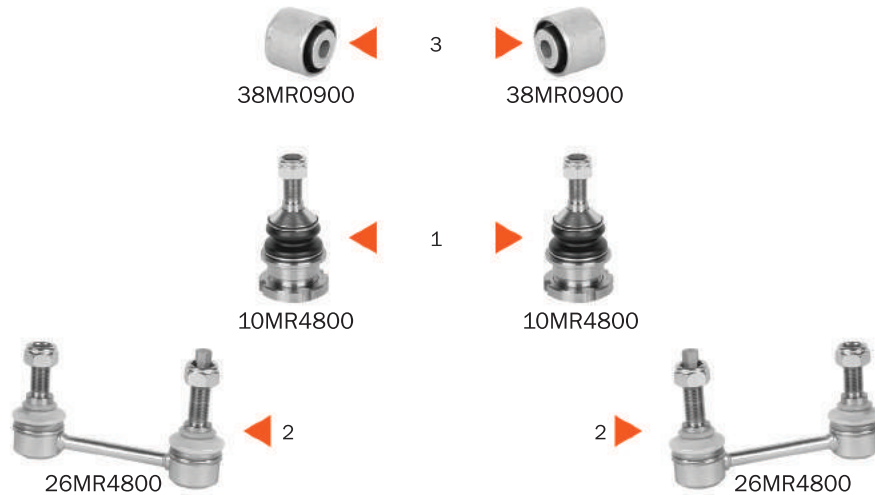

NO	ASMETAL CODE	DESCRIPTION	MEASURES	OEM
1	10MR4800	Ball Joint Rear	th:M16x1.5 RHT th2:M42x1.5 RHT	164 352 01 27
2	26MR4800	Stabiliser Link Rear	L:117mm	164 320 12 32
3	38MR0900	Silenblock for TCA	di:Ø12,2 do:Ø39,8	164 350 13 06

GLE

GLE (W166)
GLE COUPE (C292)



04/2015 ->

03/2015 ->

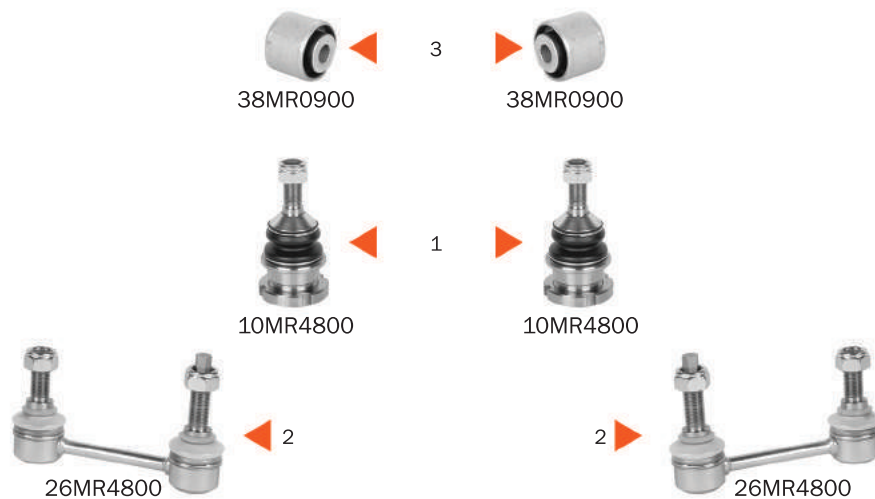

NO	ASMETAL CODE	DESCRIPTION	MEASURES	OEM
1	10MR4800	Ball Joint Rear	th:M16x1.5 RHT th2:M42x1.5 RHT	164 352 01 27
2	26MR4800	Stabiliser Link Rear	L:117mm	164 320 12 32
3	38MR0900	Silenblock for TCA	di:Ø12,2 do:Ø39,8	164 350 13 06

MERCEDES - BENZ

GLK - CLASS

GLK - CLASS (X 204)



06 / 2008 -- >

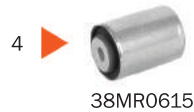
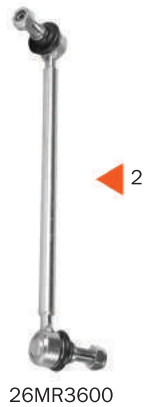

NO	ASMETAL CODE	DESCRIPTION	MEASURES	OEM
1	11MR00	Silentblock Bushing	di:Ø14 do:Ø40	204 352 00 27
2	26MR3600	Stabiliser Link Left	L:306mm	204 320 37 89
3	26MR3601	Stabiliser Link Right	L:306mm	204 320 38 89
4	38MR0615	Silentblock for TCA	di:Ø12,2 do:Ø51,2	222 352 08 65
5	38MR0617	Silentblock for TCA	di:Ø12,2 do:Ø38,5	230 352 15 65
6	38MR0705	Silentblock for TCA	di:Ø24 do:Ø44,5	203 333 02 14
7	38MR0706	Silentblock for TCA	di:Ø15 do:Ø70,5	204 333 11 14

MERCEDES - BENZ

GLS

GLS (X166)



11/2015 ->



NO	ASMETAL CODE	DESCRIPTION	MEASURES	OEM
1	10MR4800	Ball Joint Rear	th:M16x1,5 RHT th2:M42x1,5 RHT	164 352 01 27
2	26MR4800	Stabiliser Link Rear	L:117mm	164 320 12 32
3	38MR0900	Silentblock for TCA	di:Ø12,2 do:Ø39,8	164 350 13 06

L - LK SERIES

L 406 (309) L 406 DG
 L 408 (309) L 408 DG
 L 508 (309) L 508 DG
 L 608 (310) L 608 D
 LK 408 (309) LK 408 G

01 / 1967 - 12 / 1974
 01 / 1956 - 12 / 1978
 01 / 1969 - 12 / 1976
 01 / 1970 - 12 / 1988
 01 / 1968 - 12 / 1974

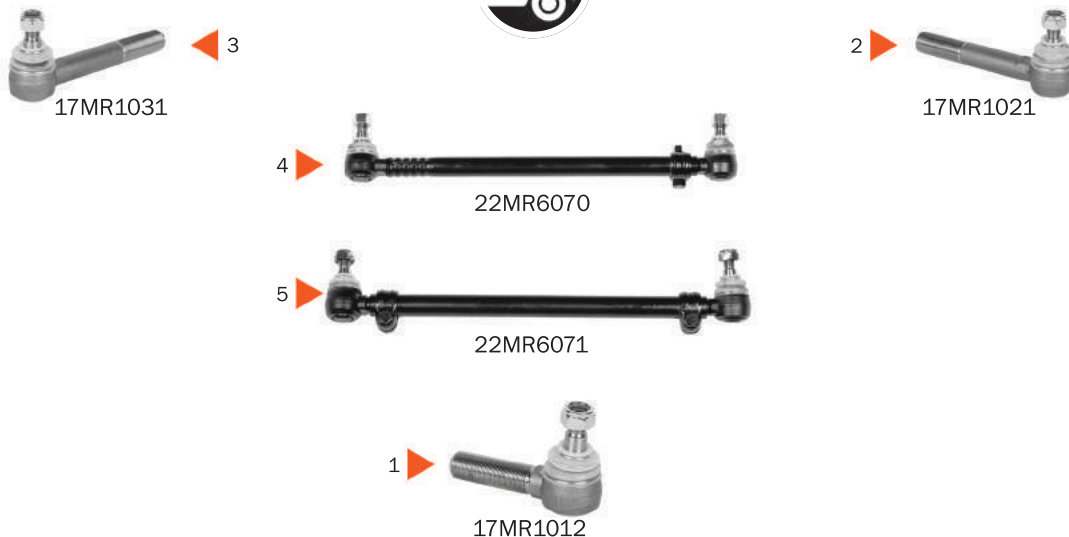

NO	ASMETAL CODE	DESCRIPTION	MEASURES	OEM
1	17MR1012	Tie Rod End	c:Ø16,2 th:MM22x1,5 RHT	A310 330 04 35
2	17MR1021	Tie Rod End	c:Ø16,3 th:MM24x1,5 RHT	A000 330 27 35
3	17MR1031	Tie Rod End	c:Ø16,3 th:MM24x1,5 LHT	A001 330 08 35
4	22MR6070	Tie Rod Center	th1:M14x1,5 RHT	309 460 03 05
5	22MR6071	Tie Rod Center	th1:M14x1,5 RHT	309 460 25 05

MERCEDES - BENZ

HECKFLOSSE, HENSCHEL

HECKFLOSSE (W 110 , W111 , W112)



04 / 1961 - 02 / 1968



17MR1530

1



17MR1550

2



17MR1550

1



17MR1530



21MR1560

3

NO	ASMETAL CODE	DESCRIPTION	MEASURES	OEM
1	17MR1530	Tie Rod End Outer	c:Ø12,6 th:MM14x1,5 RHT	000 338 07 10
2	17MR1550	Tie Rod End Inner	c:Ø12,6 th:MM14x1,5 LHT	000 338 08 10
3	21MR1560	Tie Rod Adjustable	c:Ø12,6 th:M10x1.0 RHT	107 330 01 03

HENSCHEL 2-t



02 / 1973 - 12 / 1977



10MR1000

1



10MR1000

NO	ASMETAL CODE	DESCRIPTION	MEASURES	OEM
1	10MR1000	Ball Joint	th:M16x1.5 RHT cp:1/10 cs:Ø20,3 do:Ø26	000 320 00 28

MERCEDES - BENZ

M - CLASS

M - CLASS (W 163)



02 / 1998 - 06 / 2005



5



1



6



NO	ASMETAL CODE	DESCRIPTION	MEASURES	OEM
1	10MR4500	Ball Joint	th:M14x1.5 RHT cp:1/6 cs:Ø16,2 th2:M42x1.5 RHT	163 330 01 35
2	10MR4600	Ball Joint Rear	th:M14x1.5 RHT c:Ø20 th2:M42x1.5 RHT	163 350 01 13
3	17MR4500	Tie Rod End Left	c:Ø15,1 th:FM16x1,5 RHT	163 330 01 03
4	17MR4501	Tie Rod End Right	c:Ø15,1 th:FM16x1,5 RHT	163 330 04 03
5	20MR4500	Axial Joint	th:MM16x1,5 RHT L:160mm	163 338 02 15
6	26MR2000	Stabiliser Link Rear	L:222,3mm Plastic	163 320 00 32

MERCEDES - BENZ

M - CLASS

M - CLASS (W 164)



07/2005 - 06/2012

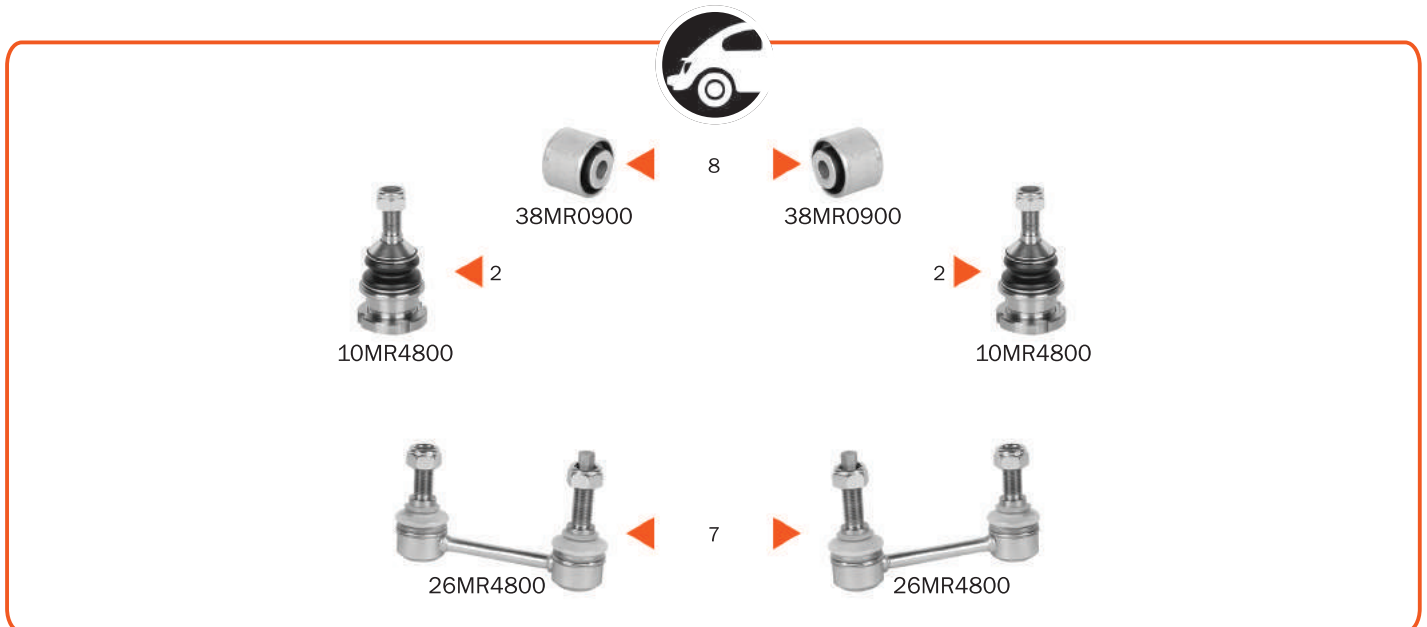
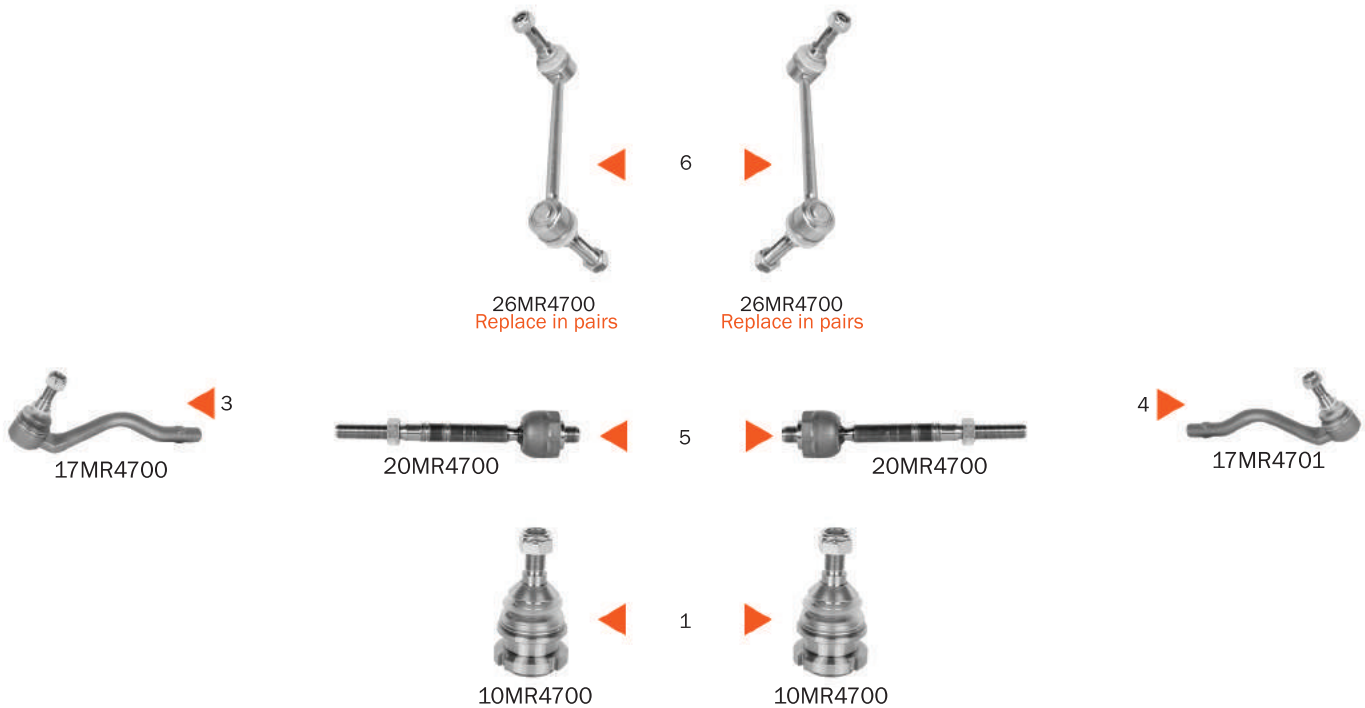

NO	ASMETAL CODE	DESCRIPTION	MEASURES	OEM
1	10MR4700	Ball Joint	th:M16x1.5 RHT th2:M42x1.5 RHT	164 330 09 35
2	10MR4800	Ball Joint Rear	th:M16x1.5 RHT th2:M42x1.5 RHT	164 352 03 27
3	17MR4700	Tie Rod End Left	c:Ø15 th:FM14x1,5 RHT	164 330 11 03
4	17MR4701	Tie Rod End Right	c:Ø15 th:FM14x1,5 RHT / 0,83 kg	164 330 12 03
5	20MR4700	Axial Joint	th:MM16x1,5 RHT L:208,5mm	164 460 00 05
6	26MR4700	Stabiliser Link	L:205mm	164 320 13 32
7	26MR4800	Stabiliser Link Rear	L:117mm	164 320 12 32
8	38MR0900	Silenblock for TCA	di:Ø12,2 do:Ø39,8	164 350 13 06

MERCEDES - BENZ

M - CLASS

M - CLASS (W 166)



06 / 2011 -- >

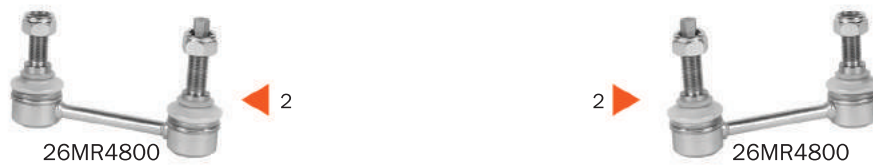
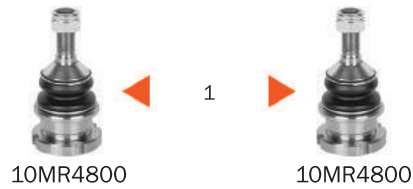
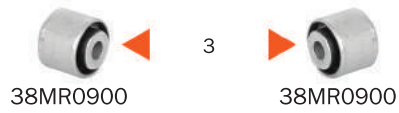

NO	ASMETAL CODE	DESCRIPTION	MEASURES	OEM
1	10MR4800	Ball Joint Rear	th:M16x1.5 RHT th2:M42x1.5 RHT	164 352 01 27
2	26MR4800	Stabiliser Link Rear	L:117mm	164 320 12 32
3	38MR0900	Silenblock for TCA	di:Ø12,2 do:Ø39,8	164 350 13 06

MERCEDES - BENZ

PACODE

PACODE (W 113)



01/1963 - 03/1971



17MR1530

1



17MR1550

2



17MR1550

1



17MR1530



21MR1560

3

NO	ASMETAL CODE	DESCRIPTION	MEASURES	OEM
1	17MR1530	Tie Rod End	c:Ø12,6 th:MM14x1,5 RHT	000 338 07 10
2	17MR1550	Tie Rod End	c:Ø12,6 th:MM14x1,5 LHT	000 338 08 10
3	21MR1560	Tie Rod Adjustable	c:Ø12,6 th:M10x1.0 RHT	107 330 01 03

PONTON

PONTON (W120 , W 121, W 128, W180)



07/1953 - 12/1963



17MR1530

1



17MR1550

2



17MR1530

1



17MR1550

2

NO	ASMETAL CODE	DESCRIPTION	MEASURES	OEM
1	17MR1530	Tie Rod End	c:Ø12,6 th:MM14x1,5 RHT	000 338 07 10
2	17MR1550	Tie Rod End	c:Ø12,6 th:MM14x1,5 LHT	000 338 08 10

MERCEDES - BENZ

R - CLASS

R-CLASS (W251, V251)



01/2006 -- >

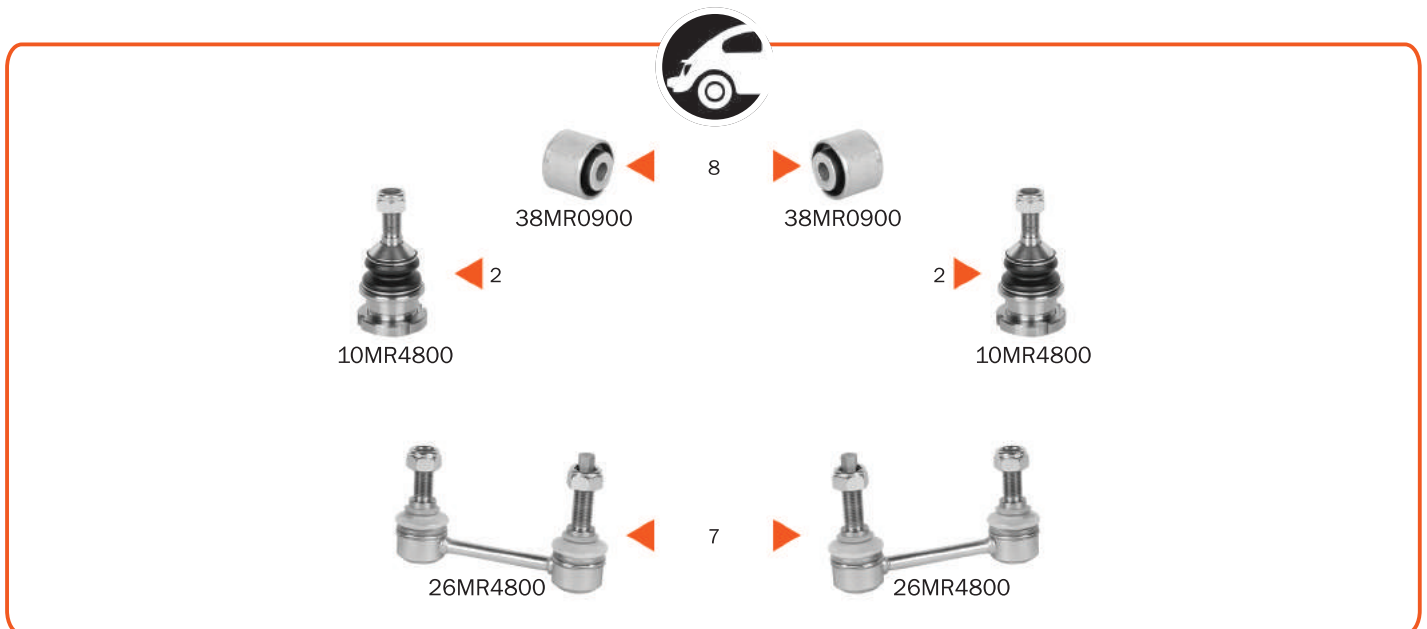
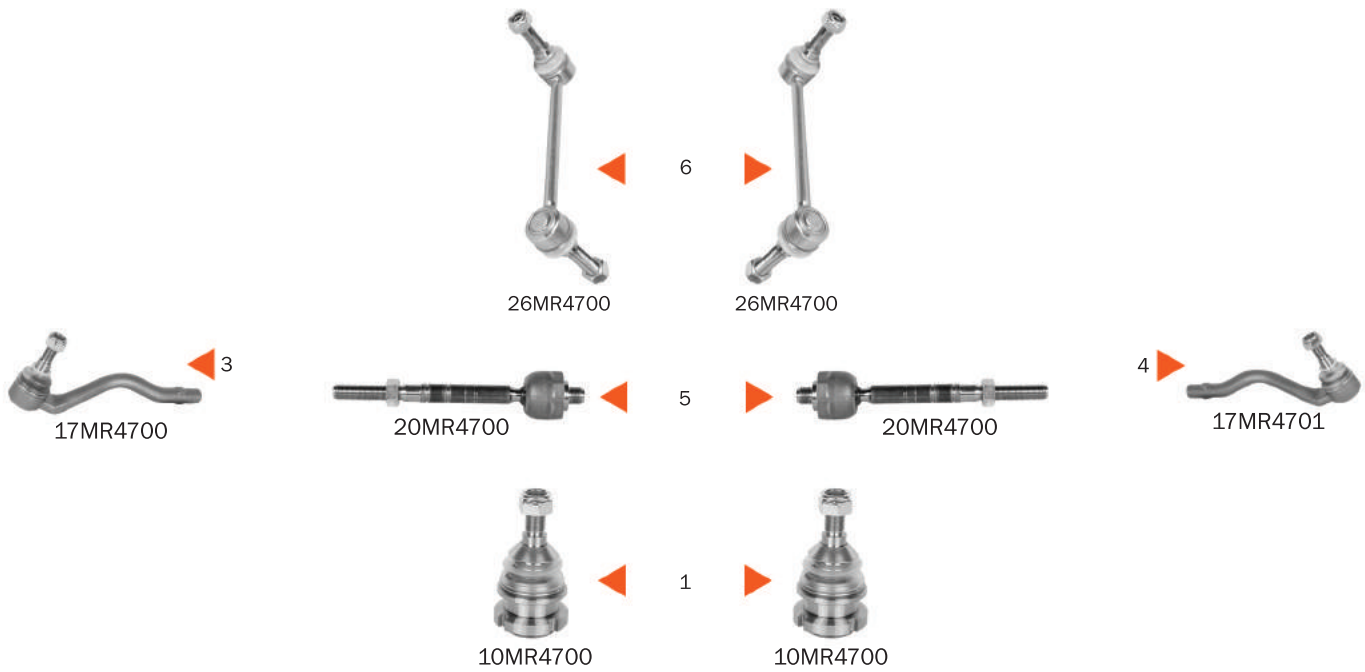

NO	ASMETAL CODE	DESCRIPTION	MEASURES	OEM
1	10MR4700	Ball Joint	th:M16x1.5 RHT th2:M42x1.5 RHT	164 330 09 35
2	10MR4800	Ball Joint Rear	th:M16x1.5 RHT th2:M42x1.5 RHT	164 352 03 27
3	17MR4700	Tie Rod End Left	c:Ø15 th:FM14x1,5 RHT	164 330 11 03
4	17MR4701	Tie Rod End Right	c:Ø15 th:FM14x1,5 RHT / 0,83 kg	164 330 12 03
5	20MR4700	Axial Joint	th:MM16x1,5 RHT L:208,5mm	164 460 00 05
6	26MR4700	Stabiliser Link	L:205mm	164 320 13 32
7	26MR4800	Stabiliser Link Rear	L:117mm	164 320 12 32
8	38MR0900	Silenblock for TCA	di:Ø12,2 do:Ø39,8	164 350 13 06

MERCEDES - BENZ

S-CLASS

S-CLASS (W 108, W 109)



01/1966 - 08/1972



17MR1530

1



17MR1550

2



17MR1550

1



17MR1530



21MR1560

3



21MR1560

NO	ASMETAL CODE	DESCRIPTION	MEASURES	OEM
1	17MR1530	Tie Rod End	c:Ø12,6 th:MM14x1,5 RHT	000 338 07 10
2	17MR1550	Tie Rod End	c:Ø12,6 th:MM14x1,5 LHT	000 338 08 10
3	21MR1560	Tie Rod Adjustable	c:Ø12,6 th:M10x1.0 RHT	107 330 01 03

MERCEDES - BENZ

S-CLASS

S-CLASS (W 116)

S-CLASS (W 126)

S-CLASS (C126)

08 / 1972 - 07 / 1980

10 / 1979 - 06 / 1991

10 / 1981 - 06 / 1991



6 ▶



22MR2370

5 ▶



21MR2360

◀ 2



17MR1530

◀ 3



17MR1550

2 ▶



17MR1530

3 ▶



17MR1550

For Armored Vehicles

◀ 4 ▶



17MR2330



17MR2330

◀ 1 ▶



10MR2355



10MR2355

◀ 7 ▶



26MR2300



26MR2300



NO	ASMETAL CODE	DESCRIPTION	MEASURES	OEM
1	10MR2355	Ball Joint	th:M14x1.5 RHT cp:1/10 cs:Ø18,3 do:Ø45,4	116 333 09 27
2	17MR1530	Tie Rod End	c:Ø12,6 th:MM14x1,5 RHT	000 338 07 10
3	17MR1550	Tie Rod End	c:Ø12,6 th:MM14x1,5 LHT	000 338 08 10
4	17MR2330	Tie Rod End	c:Ø12,6 th:MM14x1,5 RHT	000 338 41 10
5	21MR2360	Rod Assembly	c:Ø12,6 th:M10x1.0 RHT	123 330 18 03
6	22MR2370	Tie Rod Center	th1:M10x1.0 RHT L:476mm	123 460 15 05
7	26MR2300	Stabiliser Link	L:50,75mm Plastic	115 320 15 89

MERCEDES - BENZ

S-CLASS

S-CLASS (W 140)
S-CLASS (S 140)



02 / 1991 - 10 / 1998
09 / 1992 - 02 / 1999

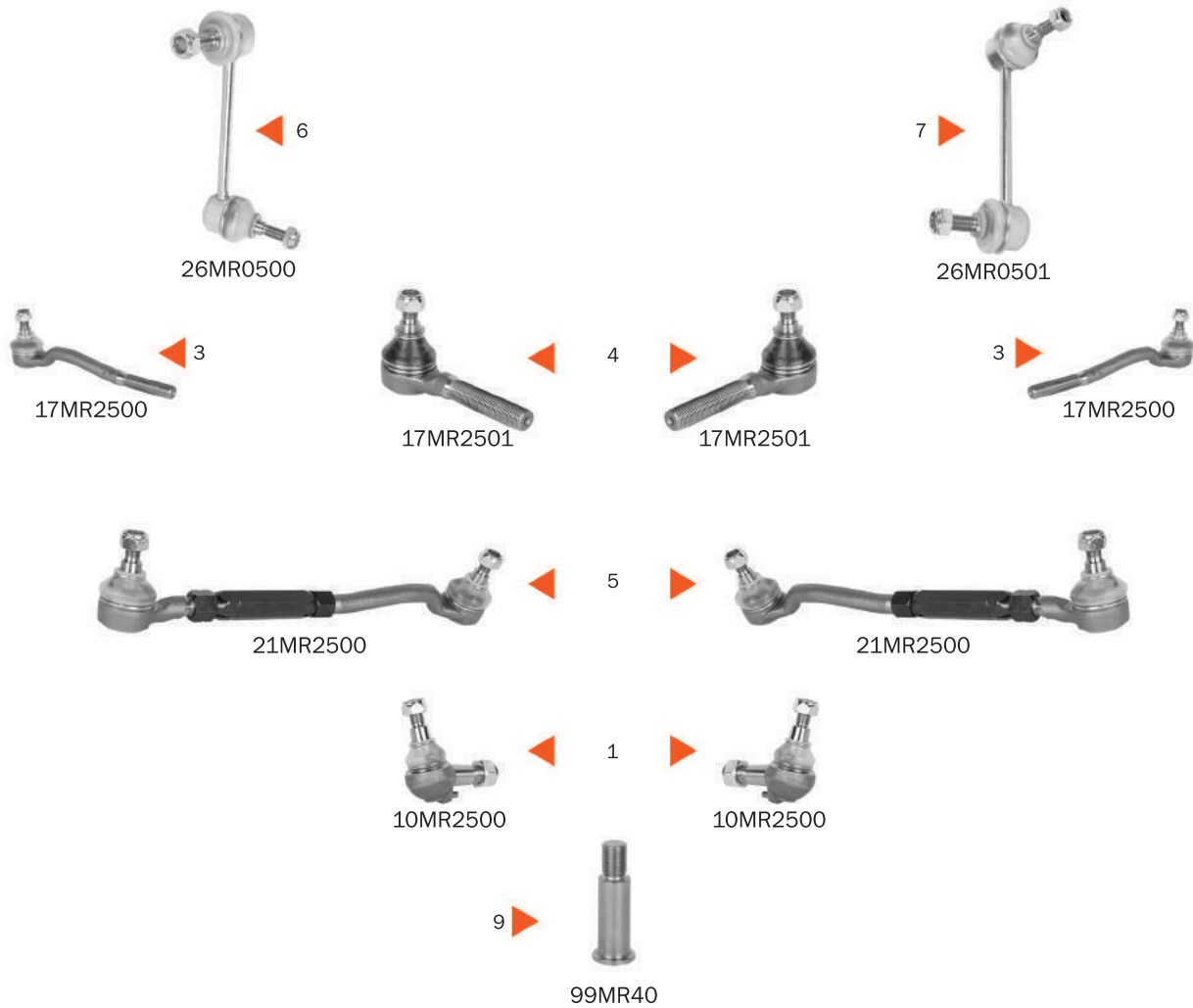

NO	ASMETAL CODE	DESCRIPTION	MEASURES	OEM
1	10MR2500	Ball Joint	th:M14x1.5 RHT cp:1/10 cs:Ø17,8	140 333 03 27
2	11MR00	Silentblock Bushing	di:Ø14 do:Ø40	204 352 00 27
3	17MR2500	Tie Rod End	c:Ø14,6 th:MM16x1,5 RHT	001 330 62 35
4	17MR2501	Tie Rod End	c:Ø14,6 th:MM16x1,5 LHT	001 330 63 35
5	21MR2500	Tie Rod	c:Ø14,6 th:M12x1.5 RHT	140 330 00 03
6	26MR0500	Stabiliser Link Left	L:152,5mm	140 320 11 89
7	26MR0501	Stabiliser Link Right	L:152,5mm	140 320 12 89
8	26MR1305	Stabiliser Link Rear	L:230mm	140 320 35 89
9	99MR40	Bearing Journal		606 202 01 20

MERCEDES - BENZ

S-CLASS

S-CLASS (W 220)



10 / 1998 - 08 / 2005

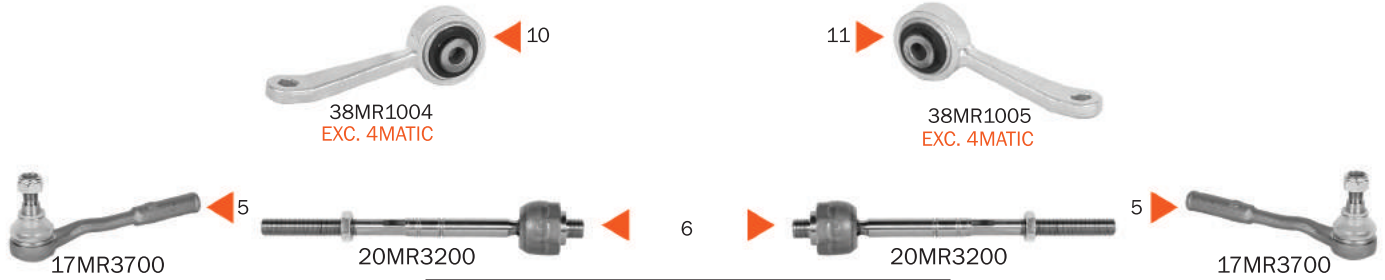

Lower

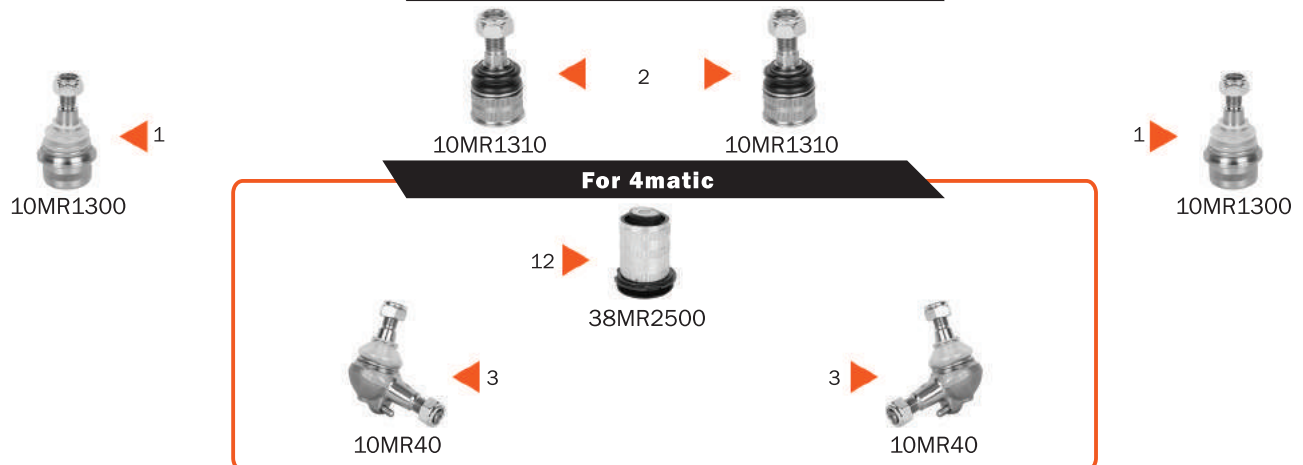

For 4matic

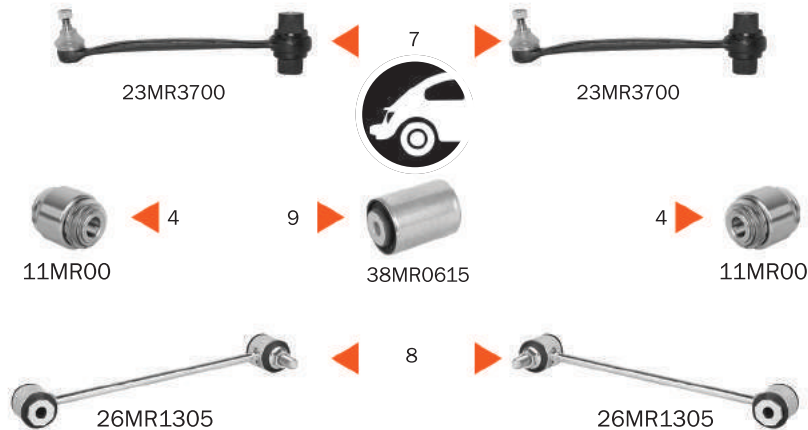

NO	ASMETAL CODE	DESCRIPTION	MEASURES	OEM
1	10MR1300	Ball Joint Lower	th:M14x1.5 RHT cp:1/10 cs:Ø17,1 do:Ø41,25	220 333 07 27
2	10MR1310	Ball Joint Lower	th:M14x1.5 RHT do:Ø34,3	211 323 00 68
3	10MR40	Ball Joint Lower	th:M14x1.5 RHT cp:1/6 cs:Ø15,9	211 330 03 35
4	11MR00	Silentblock Bushing	di:Ø14 do:Ø40	204 352 00 27
5	17MR3700	Tie Rod End	c:Ø16,6 th:FM14x1,5 RHT	230 330 04 03
6	20MR3200	Axial Joint	th:MM16x1,5 RHT L:241,5mm	230 338 00 15
7	23MR3700	TCA Lower Rear		220 350 04 53
8	26MR1305	Stabiliser Link	L:230mm	220 320 36 89
9	38MR0615	Silentblock for TCA	di:Ø12,2 do:Ø51,2	222 352 08 65
10	38MR1004	Stabiliser Link Left	di:Ø14,2 do:Ø60	220 320 15 89
11	38MR1005	Stabiliser Link Right	di:Ø14,2 do:Ø60	220 320 16 89
12	38MR2500	Silentblock for TCA	di:Ø15 do:Ø60	210 333 68 14

MERCEDES - BENZ

S-CLASS

S-CLASS (W 221)



10 / 2005 -->



NO	ASMETAL CODE	DESCRIPTION	MEASURES	OEM
1	11MR00	Silentblock Bushing	di:Ø14 do:Ø40	204 352 00 27
2	38MR0615	Silentblock for TCA	di:Ø12,2 do:Ø51,2	222 352 08 65

SL

SL (R 107)
SL COUPE (C 107)



05 / 1971 - 09 / 1989
01 / 1972 - 09 / 1981

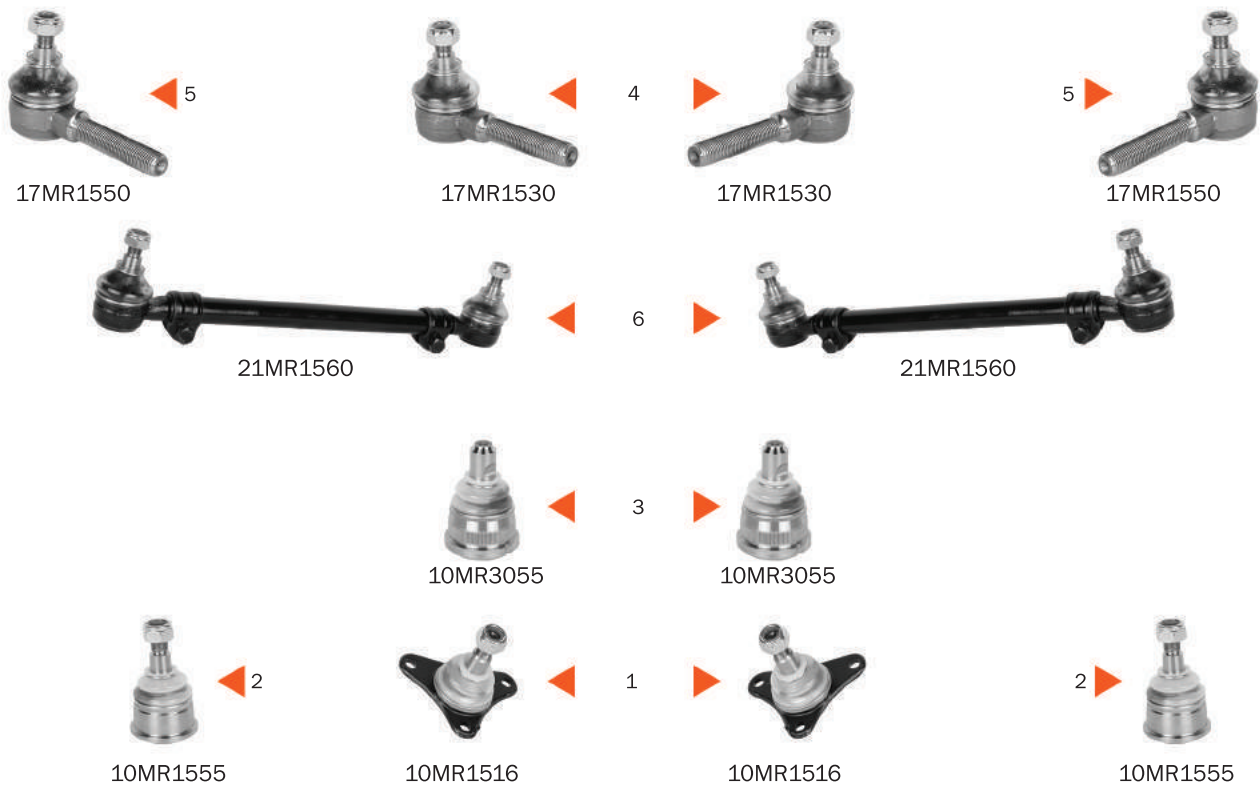

NO	ASMETAL CODE	DESCRIPTION	MEASURES	OEM
1	10MR1516	Ball Joint Upper	th:M12x1.25 RHT cp:1/10 cs:Ø14,35	115 333 08 27
2	10MR1555	Ball Joint Lower	th:M14x1.5 RHT cp:1/10 cs:Ø16 do:Ø48,35	115 333 10 27
3	10MR3055	Ball Joint	c:Ø18 do:Ø46,4	124 333 03 27
4	17MR1530	Tie Rod End Inner	c:Ø12,6 th:MM14x1,5 RHT	000 338 52 10
5	17MR1550	Tie Rod End Outer	c:Ø12,6 th:MM14x1,5 LHT	000 338 50 10
6	21MR1560	Tie Rod Adjustable	c:Ø12,6 th:M10x1.0 RHT	107 330 01 03

MERCEDES - BENZ

SL

SL (R 129)



03 / 1989 - 10 / 2001

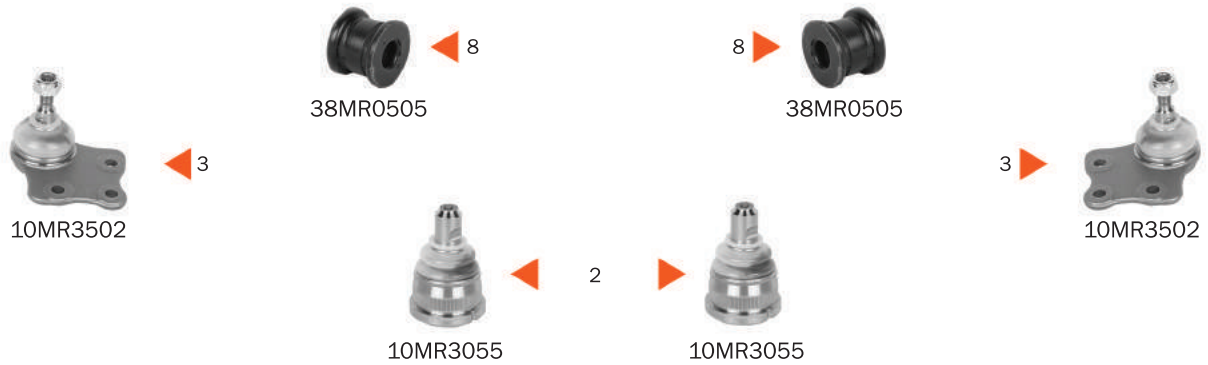

03/2000 -->

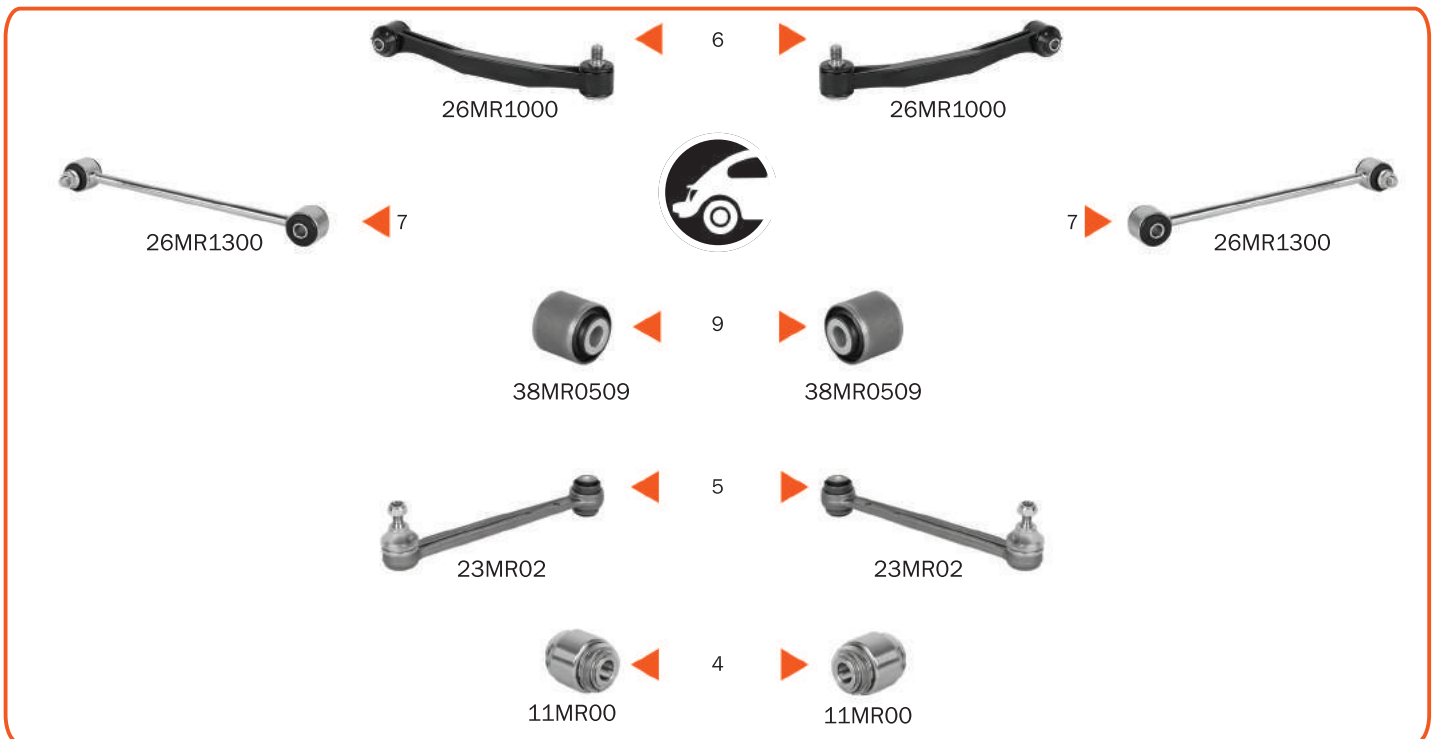
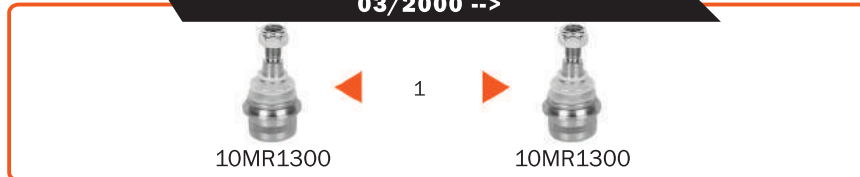

NO	ASMETAL CODE	DESCRIPTION	MEASURES	OEM
1	10MR1300	Ball Joint Front Lower	th:M14x1.5 RHT cp:1/10 cs:Ø17,1 do:Ø41,25	220 333 07 27
2	10MR3055	Ball Joint Front Lower	c:Ø18 do:Ø46,4	124 333 03 27
3	10MR3502	Ball Joint	th:M10x1.5 RHT cp:1/10 cs:Ø13	000 330 10 07
4	11MR00	Silentblock Bushing	di:Ø14 do:Ø40	204 352 00 27
5	23MR02	Stabiliser Link Rear	c:1:6 th:M10x1.25 RHT L:245mm	210 350 21 53
6	26MR1000	Stabiliser Link Rear	L:197,4mm Plastic	124 320 02 89
7	26MR1300	Stabiliser Link Rear	L:260mm	211 320 33 89
8	38MR0505	Stabiliser Mounting	di:Ø18,5 do:Ø39,5	124 323 23 85
9	38MR0509	Silentblock for TCA	di:Ø12,2 do:Ø36	124 352 34 65

MERCEDES - BENZ

SL

SL (R230)



10 / 2001 - 01 / 2012

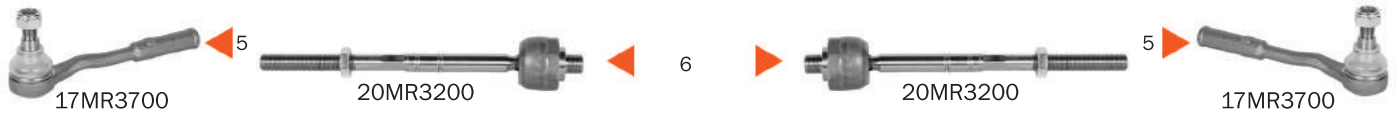

Upper

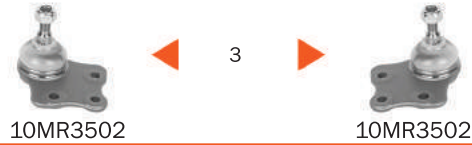

Lower



For Vehicles without ABC



AMG



NO	ASMETAL CODE	DESCRIPTION	MEASURES	OEM
1	10MR1300	Ball Joint Lower	th:M14x1.5 RHT cp:1/10 cs:Ø17,1 do:Ø41,25	220 333 07 27
2	10MR1310	Ball Joint Lower	th:M14x1.5 RHT do:Ø34,3	211 323 00 68
3	10MR3502	Ball Joint Upper	th:M10x1.5 RHT cp:1/10 cs:Ø13	000 330 10 07
5	17MR3700	Tie Rod End	c:Ø16,6 th:FM14x1,5 RHT	230 330 04 03
6	20MR3200	Axial Joint	th:MM16x1,5 RHT L:241,5mm	230 338 00 15
7	23MR3500	TCA Left		211 330 43 11
8	23MR3501	TCA Right		211 330 44 11
10	38MR0511	Silentblock for TCA	do:Ø70,4	211 333 10 14
11	38MR0512	Silentblock for TCA	do:Ø70,6	211 333 11 14
14	38MR0705	Silentblock for TCA	di:Ø24 do:Ø44,5	203 333 02 14

MERCEDES - BENZ

SL

SL (R230)



10 / 2001 - 01 / 2012

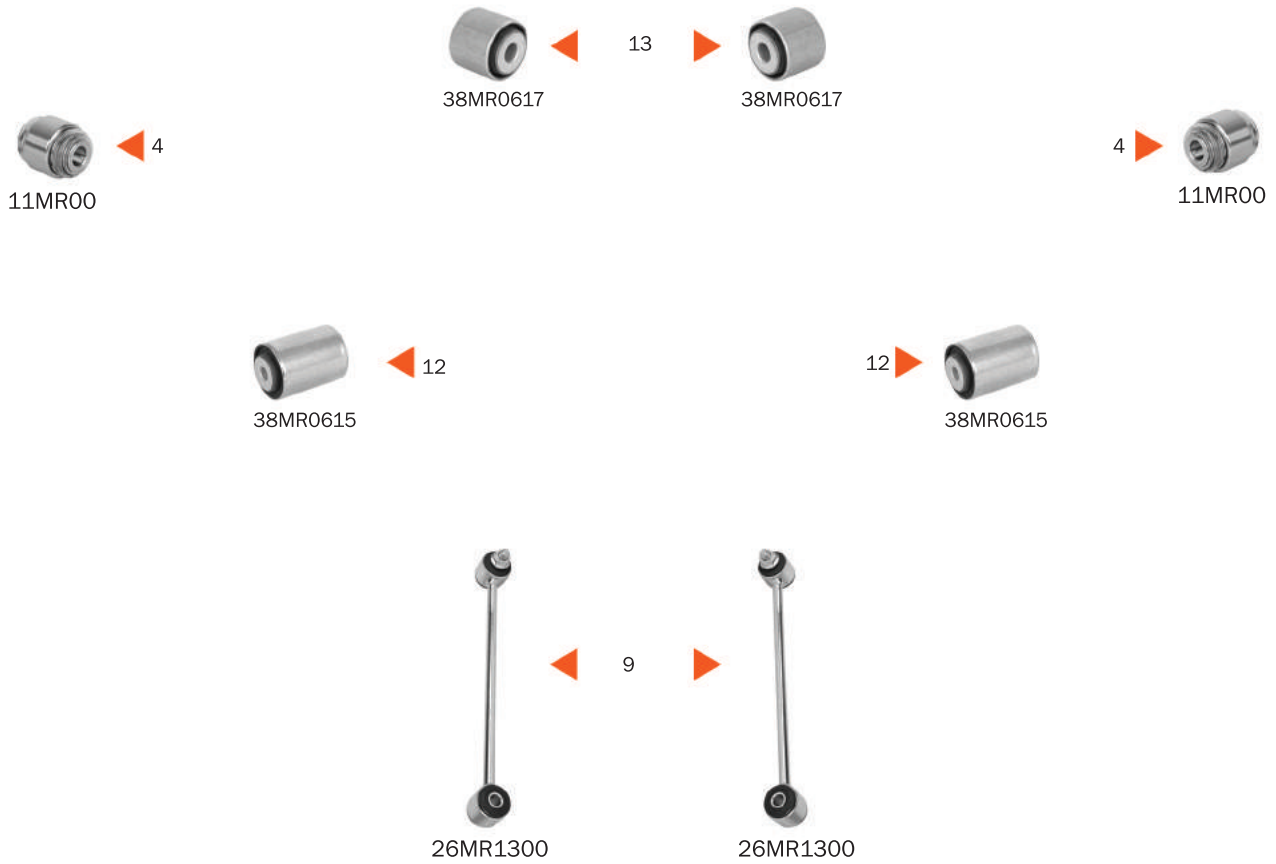

NO	ASMETAL CODE	DESCRIPTION	MEASURES	OEM
4	11MR00	Silentblock Bushing	di:Ø14 do:Ø40	204 352 00 27
9	26MR1300	Stabiliser Link Rear	L:260mm	211 320 33 89
12	38MR0615	Silentblock for TCA	di:Ø12,2 do:Ø51,2	222 352 08 65
13	38MR0617	Silent Block for TCA	di:Ø12,2 do:Ø38,5	230 352 15 65

MERCEDES - BENZ

SL

SL (R231)



01/2012 -->

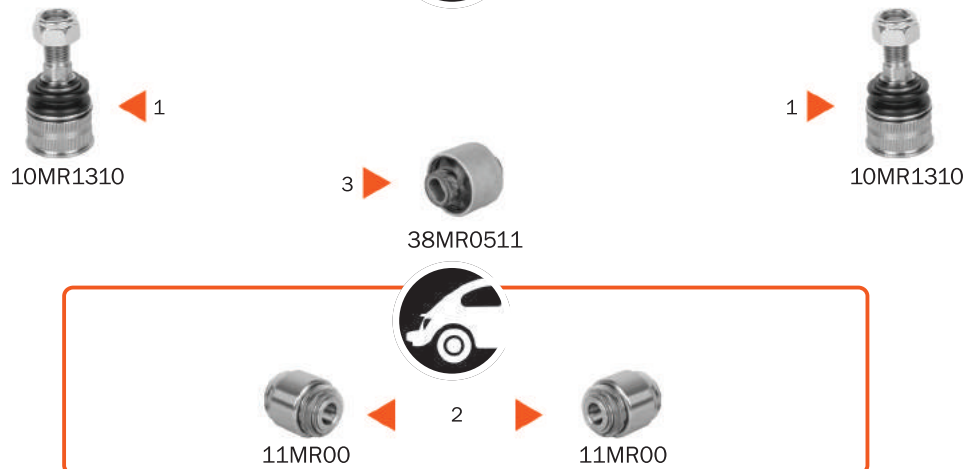

NO	ASMETAL CODE	DESCRIPTION	MEASURES	OEM
1	10MR1310	Ball Joint Lower	th:M14x1.5 RHT do:Ø34,3	211 323 00 68
2	11MR00	Silentblock Bushing	di:Ø14 do:Ø40	204 352 00 27
3	38MR0511	Silentblock for TCA	do:Ø70,4	211 333 10 14

SLC

SLC (R172)



01/2016 ->

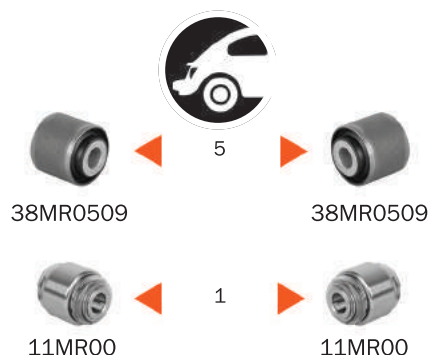

NO	ASMETAL CODE	DESCRIPTION	MEASURES	OEM
1	11MR00	Silentblock Bushing	di:Ø14 do:Ø40	204 352 00 27
2	23MR3210	TCA Upper Left		204 330 43 11
3	23MR3211	TCA Upper Right		204 330 44 11
4	38MR0706	Silentblock for TCA	di:Ø15 do:Ø70,5	204 333 11 14
5	38MR0509	Silentblock for TCA	di:Ø12,2 do:Ø36	124 352 34 65

MERCEDES - BENZ

SLK

SLK (R 170)



04 / 1996 - 04 / 2004

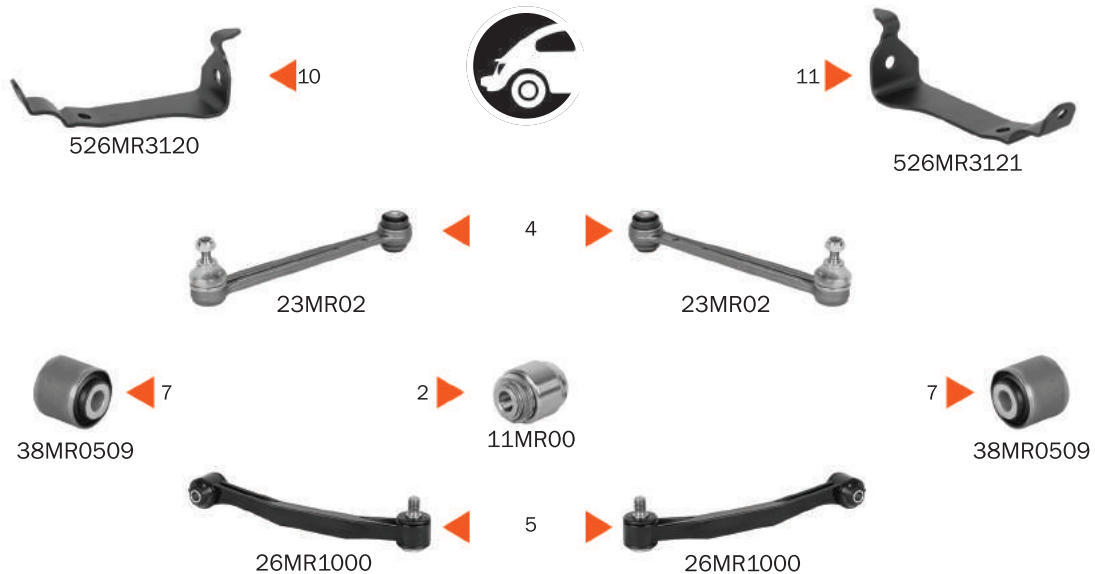
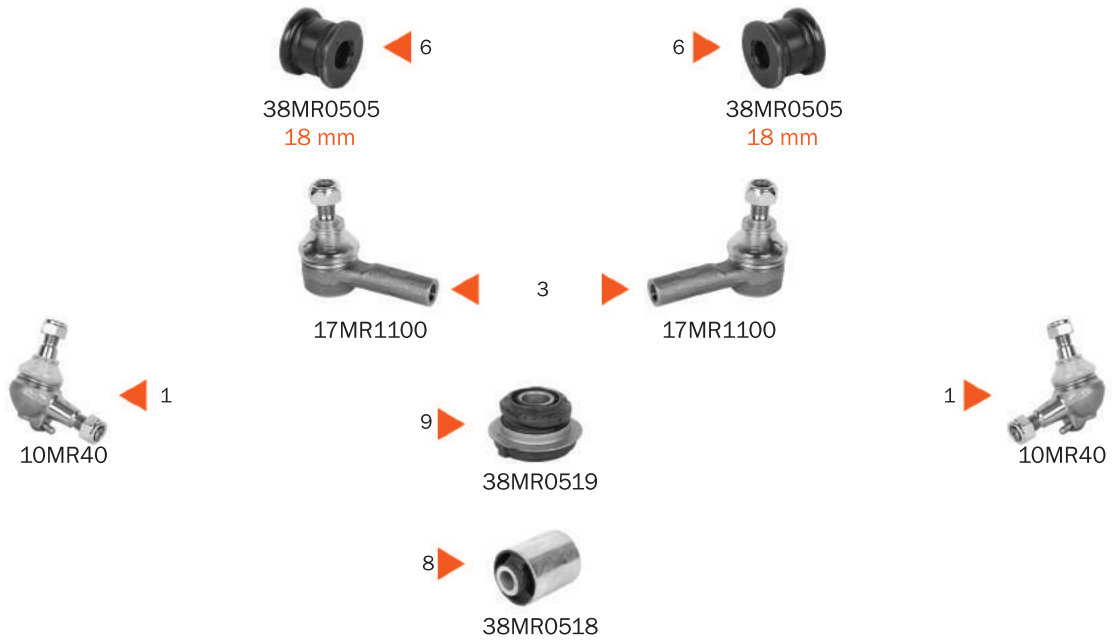

NO	ASMETAL CODE	DESCRIPTION	MEASURES	OEM
1	10MR40	Ball Joint	th:M14x1.5 RHT cp:1/6 cs:Ø15,9	211 330 03 35
2	11MR00	Silentblock Bushing	di:Ø14 do:Ø40	204 352 00 27
3	17MR1100	Tie Rod End	c:Ø14,6 th:FM12x1,5 RHT	001 330 77 35
4	23MR02	Stabiliser Link Rear	c:1:6 th:M10x1.25 RHT L:245mm	210 350 21 53
5	26MR1000	Stabiliser Link Rear	L:197,4mm Plastic	124 320 02 89
6	38MR0505	Stabiliser Mounting	di:Ø18,5 do:Ø39,5	124 323 23 85
7	38MR0509	Silentblock for TCA	di:Ø12,2 do:Ø36	124 352 34 65
8	38MR0518	Silent Block for TCA	di:Ø14,2 do:Ø60,2	202 333 64 14
9	38MR0519	Silent Block for TCA	di:Ø20	202 333 67 14
10	526MR3120	Bracket Rear Left		202 323 08 40
11	526MR3121	Bracket Rear Right		202 323 09 40

MERCEDES - BENZ

SLK

SLK (R 171)



03/2004 - 02/2011

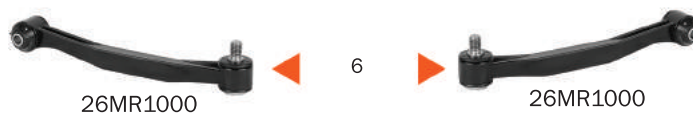
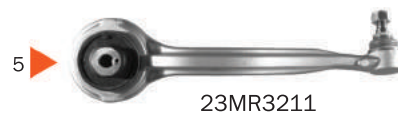

NO	ASMETAL CODE	DESCRIPTION	MEASURES	OEM
1	11MR00	Silentblock Bushing	di:Ø14 do:Ø40	204 352 00 27
2	17MR3200	Tie Rod End Right	c:Ø16 th:FM14x1,5 RHT	203 330 40 03
3	17MR3201	Tie Rod End Left	c:Ø16 th:FM14x1,5 RHT	203 330 39 03
4	23MR3210	TCA Upper Left		203 330 01 11
5	23MR3211	TCA Upper Right		203 330 02 11
6	26MR1000	Stabiliser Link Rear	L:197,4mm Plastic	124 320 02 89
7	38MR0509	Silentblock for TCA	di:Ø12,2 do:Ø36	124 352 34 65
8	38MR0510	Silentblock for TCA	do:Ø70,6	203 333 03 14
9	38MR0705	Silentblock for TCA	di:Ø24 do:Ø44,5	203 333 02 14

MERCEDES - BENZ

SLK

SLK (R172)



02/2011 ->



23MR3210



23MR3211



38MR0706

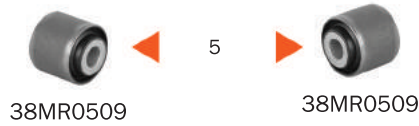

38MR0509

38MR0509



11MR00

11MR00

NO	ASMETAL CODE	DESCRIPTION	MEASURES	OEM
1	11MR00	Silentblock Bushing	di:Ø14 do:Ø40	204 352 00 27
2	23MR3210	TCA Upper Left		204 330 43 11
3	23MR3211	TCA Upper Right		204 330 44 11
4	38MR0706	Silentblock for TCA	di:Ø15 do:Ø70,5	204 333 11 14
5	38MR0509	Silentblock for TCA	di:Ø12,2 do:Ø36	124 352 34 65

MERCEDES - BENZ

SPRINTER

SPRINTER (901, 902, 903, 904, 905)



12 / 1994 - 05 / 2006

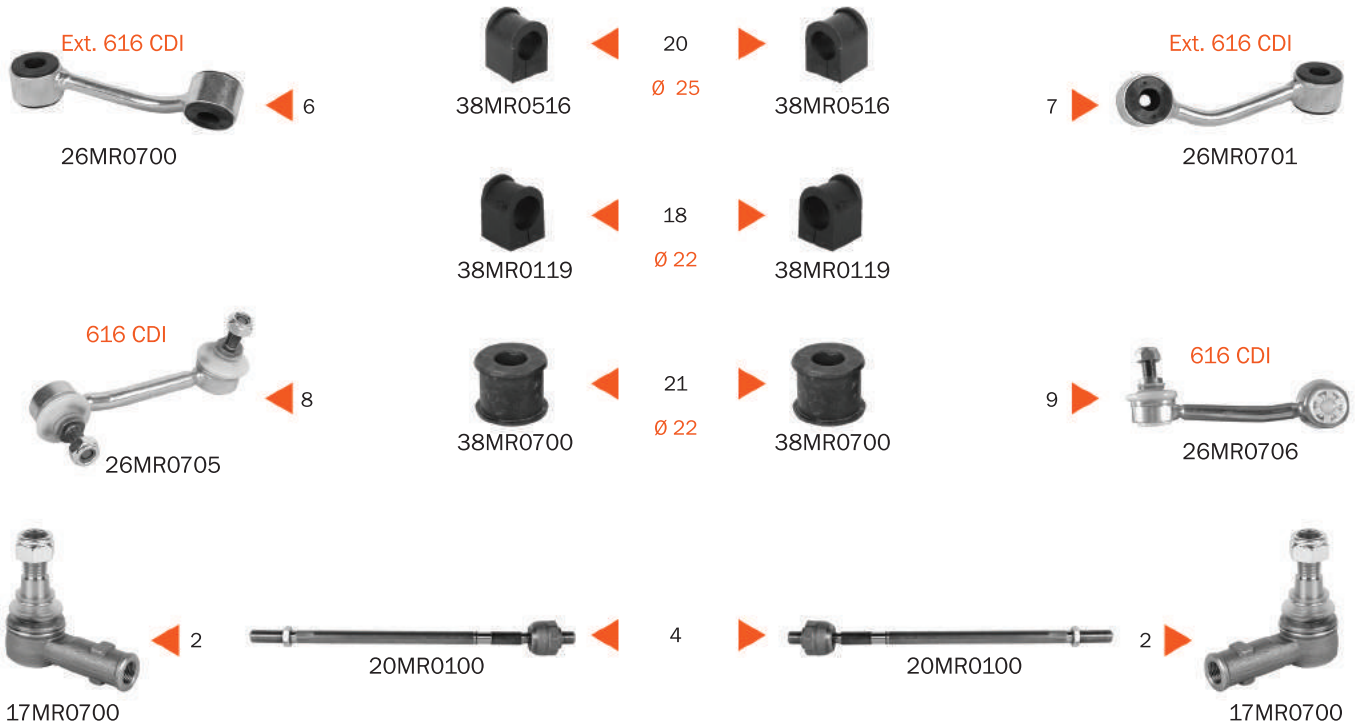

Only for 905 Dumptruck

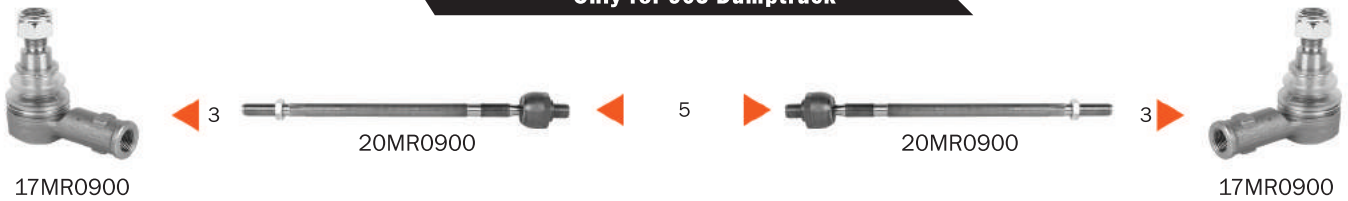

NO	ASMETAL CODE	DESCRIPTION	MEASURES	OEM
2	17MR0700	Tie Rod End	c:Ø18,15 th:FM16x1,5 RHT	901 460 01 48
3	17MR0900	Tie Rod End	c:Ø20,7 th:FM16x1,5 RHT	A 905 460 02 48
4	20MR0100	Axial Joint	th:MM16x1,5 RHT L:284mm	901 460 01 55
5	20MR0900	Axial Joint	th:MM18x1,5 RHT L:386mm	A 905 330 01 35
6	26MR0700	Stabiliser Link Left	L:115mm	901 320 02 89
7	26MR0701	Stabiliser Link Right	L:115mm	901 320 03 89
8	26MR0705	Stabiliser Link Left	L:129mm	905 320 04 89
9	26MR0706	Stabiliser Link Right	L:129mm	905 320 05 89
18	38MR0119	Stabiliser Mounting	di:Ø24,5	904 323 00 85
20	38MR0516	Stabiliser Mounting	di:Ø21,5	901 323 01 85
21	38MR0700	Stabiliser Mounting	di:Ø9 do:Ø26	901 323 02 85

MERCEDES - BENZ

SPRINTER

SPRINTER (901, 902, 903, 904, 905)



12 / 1994 - 05 / 2006

LOWER



30MR0100

11

15



38MR0110

12



30MR0101



10MR0100

1

1



10MR0100

23



40MR0100

30



99MR40

24



40MR0110

26



45MR0105

29



45MR0500

25



45MR0100

NO	ASMETAL CODE	DESCRIPTION	MEASURES	OEM
1	10MR0100	Ball Joint	th:M20x1.5 RHT cp:1/10 cs:Ø23,5 do:Ø45,4	901 333 12 27
11	30MR0100	TCA Left		901 330 24 07
12	30MR0101	TCA Right		901 330 25 07
15	38MR0110	Silentblock for TCA	di:Ø14,1 do:Ø44	901 333 02 14
23	40MR0100	Shaft Hanger	di:Ø45 h:138mm thi:52mm	901 411 03 12
24	40MR0110	Drive Shaft Kit		903 410 00 10
25	45MR0100	Engine Mounting	th1:M12x1,5 th2:M10x1,5	901 241 25 13
26	45MR0105	Engine Mounting	th1:M12x1,5 th2:M10x1,5	901 241 25 13
29	45MR0500	Mounting Automatic Transmission	di:Ø9,9 th:M12x1.75 h:86mm	601 240 07 18
30	99MR40	Bearing Journal		606 202 01 20

MERCEDES - BENZ

SPRINTER

SPRINTER (901,902,903,904,905)



12/1994 - 05/2006

Exc. 904

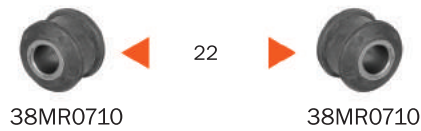

NO	ASMETAL CODE	DESCRIPTION	MEASURES	OEM
10	26MR0710	Stabiliser Link Rear	L:95mm	901 320 00 89
13	38MR0100	Spring Bush Rear	di:Ø12,2 do:Ø32,5	901 324 00 50
14	38MR0105	Spring Bush Rear	di:Ø12,2 do:Ø32,5	901 324 01 50
16	38MR0115	Spring Bush Rear	di:Ø12,2 do:Ø32,5	901 324 03 50
17	38MR0118	Stabiliser Mounting	di:Ø12,2 do:Ø32,5	901 326 00 81
19	38MR0122	Anti-roll Bar Bushing Kit	di:Ø27	901 326 01 81
22	38MR0710	Stabiliser Mounting	di:Ø12,1 do:Ø25,7	601 321 03 50
27	45MR0110	Engine Mounting	di:Ø10,1 do:Ø72,5 h:88mm	901 242 14 13
28	45MR0115	Rubber Mount	h:136,5mm h:70mm thi:57mm	901 325 01 44

MERCEDES - BENZ

SPRINTER

SPRINTER (906)

06 / 2006 -->

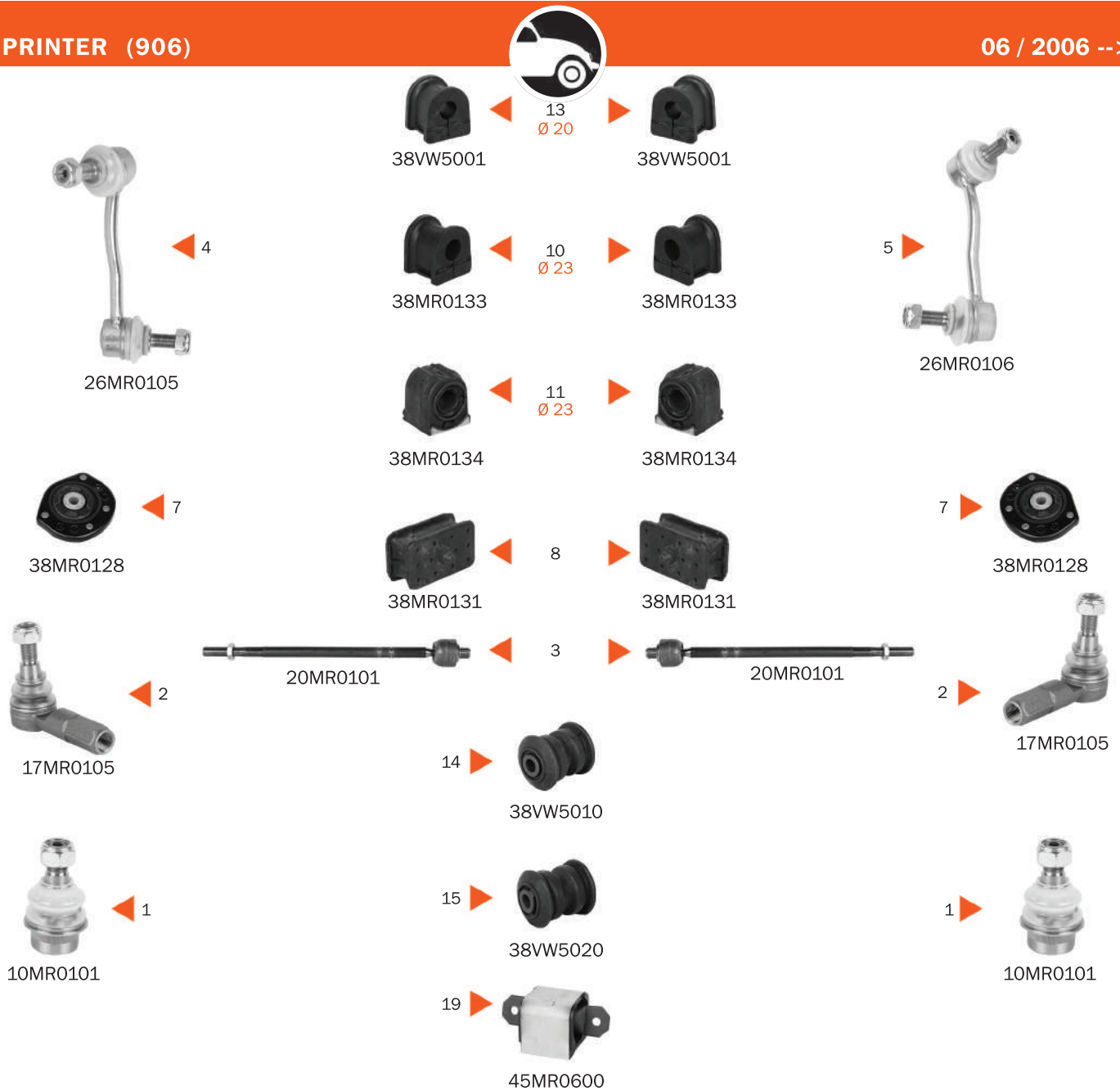

NO	ASMETAL CODE	DESCRIPTION	MEASURES	OEM
1	10MR0101	Ball Joint	th:M20x1.5 RHT cp:1/6 cs:Ø21,8 do:Ø45,3	2E0 407 151 M
2	17MR0105	Tie Rod End	c:Ø16,7 th:FM16x1,5 RHT	2E0 498 104 A
3	20MR0101	Tie Rod Axle Joint	th:MM18x1.5 RHT L:397,5mm	2E0 713 491*
4	26MR0105	Stabiliser Link Left	L:138mm	2E0 411 317 C
5	26MR0106	Stabiliser Link Right	L:138mm	2E0 411 318 C
7	38MR0128	Strut Mount	di:Ø16,75	2E0 407 181 C
8	38MR0131	Mounting Leaf Spring		906 322 06 19
10	38MR0133	Stabiliser Mounting	di:Ø22,5	2E0 411 041 F
11	38MR0134	Stabiliser Mounting	di:Ø20	2E0 411 041 F
13	38VW5001	Stabiliser Mounting	di:Ø20	2E0 411 041 E
14	38VW5010	Silentblock for TCA	di:Ø14,2 do:Ø50,5	2E0 407 523
15	38VW5020	Silentblock for TCA	di:Ø14,2 do:Ø50,5	2E0 407 253 A
19	45MR0600	Engine Mounting	h:134mm thi:74,7mm thi:64,5mm	639 242 00 13

MERCEDES - BENZ

SPRINTER

SPRINTER (906)



06 / 2006 -->



38MR0132

◀ 9



38MR0710

12



38MR0710

9 ▶



38MR0132

--> 06 / 2012



38MR0124

6



38MR0124

16 ▶



40MR0200

17 ▶



40MR0210
with FAG roller

18 ▶



40MR0211
with FAG roller

NO	ASMETAL CODE	DESCRIPTION	MEASURES	OEM
6	38MR0124	Stabiliser Mounting	di:Ø30	2D0 511 413 C
9	38MR0132	Mounting Leaf Spring		906 322 00 19
12	38MR0710	Silentblock for Stabiliser Link	di:Ø12,1 do:Ø25,7	2D0 511 413
16	40MR0200	Bearing Drive Shaft	di:Ø47 h:138mm thi:45mm	2E0 598 351 C
17	40MR0210	Bearing Drive Shaft (FAG)	di:Ø47 h:138mm thi:45mm FAG	2E0 598 351 C
18	40MR0211	Bearing Drive Shaft (FAG)	di:Ø47 h:138mm thi:45mm FAG	2E0 598 351 B

MERCEDES - BENZ

SPRINTER

SPRINTER (909)



09 / 2013 -->



LOWER



NO	ASMETAL CODE	DESCRIPTION	MEASURES	OEM
1	10MR0100	Ball Joint	th:M20x1,5 RHT cp:1/10 cs:Ø23,5 do:Ø45,4	901 333 12 27
2	17MR0700	Tie Rod End	c:Ø18,15 th:FM16x1,5 RHT	901 460 01 48
3	20MR0100	Axial Joint	th:MM16x1,5 RHT L:284mm	901 460 01 55
4	26MR0700	Stabiliser Link Left	L:115mm	901 320 02 89
5	26MR0701	Stabiliser Link Right	L:115mm	901 320 03 89
6	30MR0100	TCA Left		901 330 24 07
7	30MR0101	TCA Right		901 330 25 07
9	38MR0110	Silentblock for TCA	di:Ø14,1 do:Ø44	901 333 02 14
11	38MR0119	Stabiliser Mounting	di:Ø24,5	904 323 00 85
13	38MR0516	Stabiliser Mounting	di:Ø21,5	901 323 01 85
14	38MR0700	Stabiliser Mounting	di:Ø9 do:Ø26	901 323 02 85

MERCEDES - BENZ

SPRINTER

SPRINTER (909)



09 / 2013 -->



-> CHASS B112599



NO	ASMETAL CODE	DESCRIPTION	MEASURES	OEM
8	38MR0100	Spring Bush Rear	di:Ø12,2 do:Ø32,5	901 324 00 50
10	38MR0115	Spring Bush Rear	di:Ø12,1 do:Ø49,2	901 324 03 50
12	38MR0122	Stabiliser Mounting	di:Ø27	901 326 01 81
15	38MR0710	Silentblock for Stabiliser	di:Ø12,1 do:Ø25,7	601 321 03 50
16	40MR0100	Shaft Hanger	di:Ø45 h:138mm thi:52mm	901 411 03 12
17	40MR0110	Drive Shaft Kit		903 410 00 10
18	45MR0100	Engine Mounting	th1:M12x1,5 th2:M10x1,5	901 241 25 13
19	45MR0105	Engine Mounting	th1:M12x1,5 th2:M10x1,5	901 241 25 13
20	45MR0110	Engine Mounting	di:Ø10,1 do:Ø72,5 h:88mm	901 242 14 13
21	45MR0115	Rubber Mount	h:136,5mm h:70mm thi:57mm	901 325 01 44
22	45MR0500	Mounting Automatic Transmission	di:Ø9,9 th:M12x1.75 h:86mm	601 240 07 18
23	99MR40	Bearing Journal		606 202 01 20

MERCEDES - BENZ

SPRINTER

SPRINTER (907,910)



02 / 2018 -->

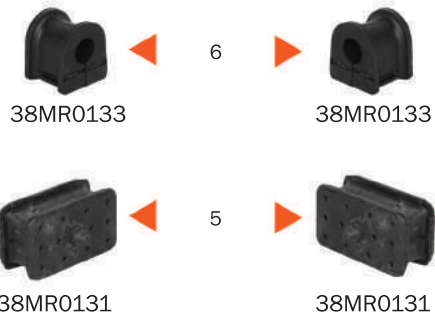

NO	ASMETAL CODE	DESCRIPTION	MEASURES	OEM
1	10MR0101	Ball Joint	th:M20x1.5 RHT cp:1/6 cs:Ø21,8 do:Ø45,3	906 330 40 07
2	26MR0105	Stabiliser Link Left	L:138mm	906 320 17 89
3	26MR0106	Stabiliser Link Right	L:138mm	906 320 18 89
4	38MR0128	Strut Mount	di:Ø16,75	906 323 05 20
5	38MR0131	Mounting Leaf Spring		906 322 06 19
6	38MR0133	Stabiliser Mounting	di:Ø22,5	906 323 16 85
7	38VW5010	Silentblock for TCA	di:Ø14,2 do:Ø50,5	906 333 00 14
8	38VW5020	Silentblock for TCA	di:Ø14,2 do:Ø50,5	906 333 01 14
9	45MR0600	Engine Mounting	h:134mm thi:74,7mm thi:64,5mm	639 242 00 13

MERCEDES - BENZ

T1 SERIES

T1 (601) (207 D, 208, 208 D, 209, 210, 210 D)
T1 (602) (307 D, 308 D, 309 D, 310, 310 D)



01/1977 - 12/1996
01/1977 - 12/1996



exc. T1 (602)



exc. T1 (602)



NO	ASMETAL CODE	DESCRIPTION	MEASURES	OEM
1	17MR1012	Tie Rod End	c:Ø16,2 th:MM22x1,5 RHT	A310 330 04 35
2	17MR1013	Tie Rod End	c:Ø16,2 th:MM22x1,5 LHT	A000 460 86 48
3	17MR1021	Tie Rod End	c:Ø16,3 th:MM24x1,5 RHT	A000 330 27 35
4	17MR1031	Tie Rod End	c:Ø16,3 th:MM24x1,5 LHT	A001 330 08 35
5	17MR6030	Tie Rod End	c:Ø16,3 th:MM22x1,5 RHT	A601 330 05 35
6	17MR6050	Tie Rod End	c:Ø16,3 th:MM22x1,5 LHT	A601 330 04 35
7	17MR6055	Tie Rod End	c:Ø16,2 th:MM24x1,5 RHT	A602 330 55 35
8	17MR6056	Tie Rod End	c:Ø16,2 th:MM24x1,5 LHT	A602 330 54 35
9	21MR1012	Tie Rod Adjustable	c:Ø16,2 th:M14x1.5 RHT	A601 460 08 05
10	22MR6070	Tie Rod Center	th1:M14x1.5 RHT	309 460 03 05
11	22MR6075	Tie Rod Center	th1:M14x1.5 RHT	A602 330 00 03
12	26MR2300	Stabiliser Link Rear	L:50,75mm Plastic	A601 430 04 35
13	38MR0121	Stabiliser Mounting	di:Ø16,1 do:Ø26	A602 321 00 50
14	38MR0710	Stabiliser Mounting	di:Ø12,1 do:Ø25,7	A601 321 03 50
15	38MR1100	Stabiliser Mounting	di:Ø23	A601 326 04 82

MERCEDES - BENZ

T2 SERIES

T2 (611) (407 D, 408 D, 409 D, 410, 410 D)

T2 (667) (507 D, 508 D, 510)

T2 (668) (609 D, 611 D)

T2 (669) (709 D)

T2 (670) (809 D, 809 DT, 811 D, 811 DK, 814 D, 814 DA, 814 DA 4Matic, 814 D Turbo)



01 / 1981 - 12 / 1995

01 / 1978 - 12 / 1996

01 / 1986 - 12 / 1996

01 / 1986 - 12 / 1996

01 / 1986 - 12 / 2011

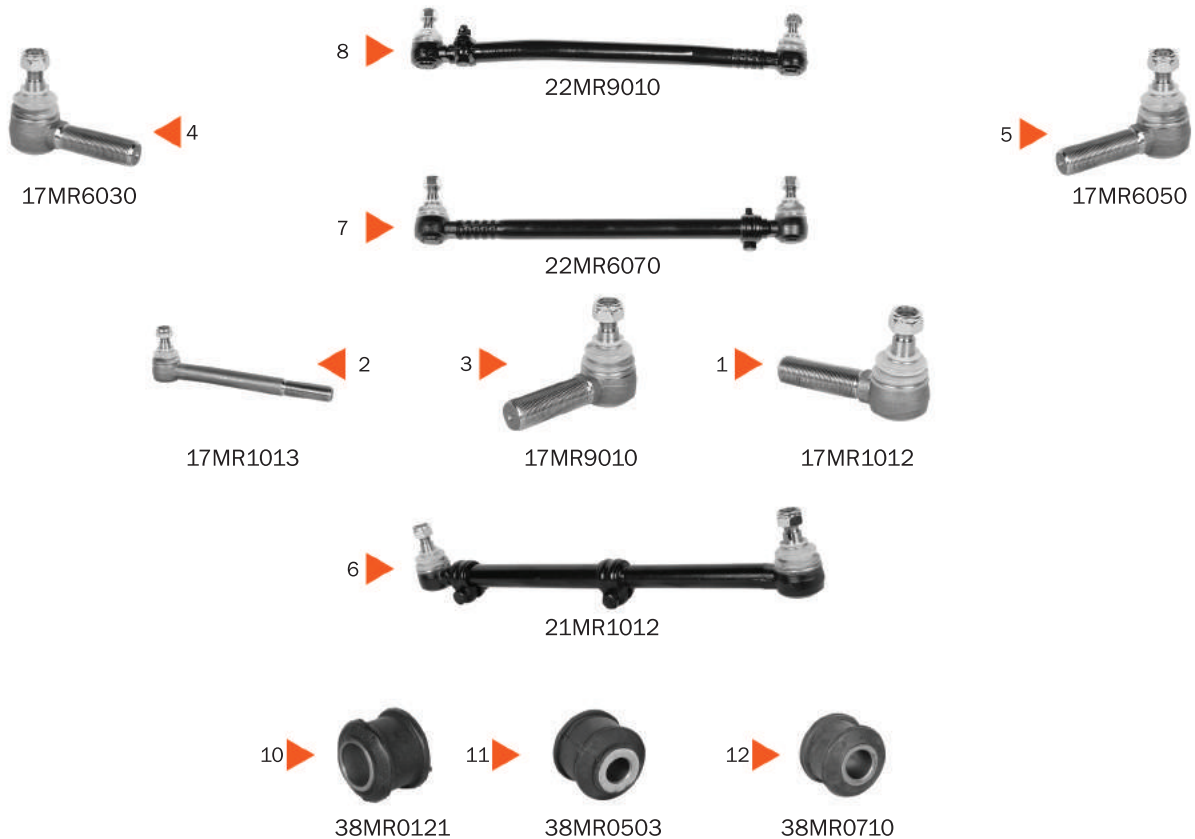

NO	ASMETAL CODE	DESCRIPTION	MEASURES	OEM
1	17MR1012	Tie Rod End	c:Ø16,2 th:MM22x1,5 RHT	A310 330 04 35
2	17MR1013	Tie Rod End	c:Ø16,2 th:MM22x1,5 LHT	A000 460 86 48
3	17MR9010	Tie Rod End	c:Ø16,25 th:MM24x1,5 RHT	A000 330 10 35
4	17MR6030	Tie Rod End	c:Ø16,3 th:MM22x1,5 RHT	A601 330 05 35
5	17MR6050	Tie Rod End	c:Ø16,3 th:MM22x1,5 LHT	A601 330 04 35
6	21MR1012	Tie Rod Adjustable	c:Ø16,2 th:M14x1.5 RHT	A601 460 08 05
7	22MR6070	Tie Rod Center	th1:M14x1.5 RHT	309 460 03 05
8	22MR9010	Tie Rod Center	th1:M14x1.5 RHT	A668 460 05 05
9	26MR2300	Stabiliser Link Rear	L:50,75mm Plastic	A601 430 04 35
10	38MR0121	Stabiliser Mounting	di:Ø16,1 do:Ø26	A602 321 00 50
11	38MR0503	Stabiliser Mounting	di:Ø12,1 do:Ø32,5	A667 320 00 73
12	38MR0710	Stabiliser Mounting	di:Ø12,1 do:Ø25,7	A601 321 03 50

MERCEDES - BENZ

Vaneo

Vaneo (414)



02 / 2002 - 07 / 2005

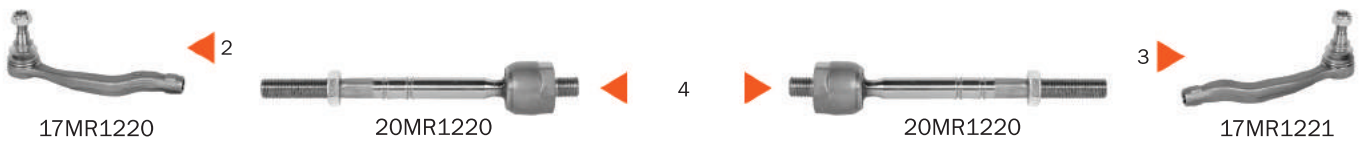

NO	ASMETAL CODE	DESCRIPTION	MEASURES	OEM
1	10MR1220	Ball Joint	th:M14x1.5 RHT cp:1/6 cs:Ø15,35	414 333 02 27
2	17MR1220	Tie Rod End Left	c:Ø16,45 th:FM14x1,5 RHT	414 460 00 05
3	17MR1221	Tie Rod End Right	c:Ø16,45 th:FM14x1,5 RHT	414 460 01 05
4	20MR1220	Axial Joint	th:MM14x1.5 RHT L:196,5mm	414 460 02 05
5	26MR1220	Stabiliser Link	L:207mm	414 320 0389

MERCEDES - BENZ

VARIO

VARIO (667) (512D)
VARIO (668) (612D , 614 D Turbo)



01 / 1996 - 12 / 2010
01 / 1996 - 12 / 2011

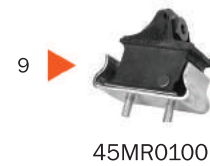
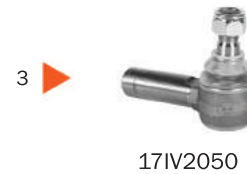
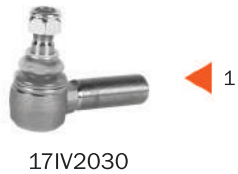

NO	ASMETAL CODE	DESCRIPTION	MEASURES	OEM
1	17IV2030	Tie Rod End	c:Ø19,7 th:MM28x1,5 RHT	A000 330 33 35
2	17IV2031	Tie Rod End	c:Ø19,7 th:MM24x1,5 RHT	A000 330 13 35
3	17IV2050	Tie Rod End	c:Ø19,7 th:MM28x1,5 LHT	A000 330 15 35
4	17IV2051	Tie Rod End	c:Ø19,7 th:MM24x1,5 LHT	A000 330 12 35
5	17MR6030	Tie Rod End	c:Ø16,3 th:MM22x1,5 RHT	A601 330 05 35
6	17MR6050	Tie Rod End	c:Ø16,3 th:MM22x1,5 LHT	A601 330 04 35
7	26MR2300	Stabiliser Link Rear	L:50,75mm Plastic	A601 430 04 35
8	38MR0503	Stabiliser Mounting	di:Ø12,1 do:Ø32,5	667 320 00 73
9	45MR0100	Engine Mounting	th1:M12x1,5 th2:M10x1,5	901 241 24 13
10	45MR0105	Engine Mounting	th1:M12x1,5 th2:M10x1,5	901 241 25 13
11	45MR0110	Engine Mounting	di:Ø10.1 do:Ø72,5 h:88mm	901 242 14 13

MERCEDES - BENZ

VITO

VITO (638)
V - CLASS (638 / 2)



02 / 1996 - 07 / 2003
09 / 1996 - 07 / 2003

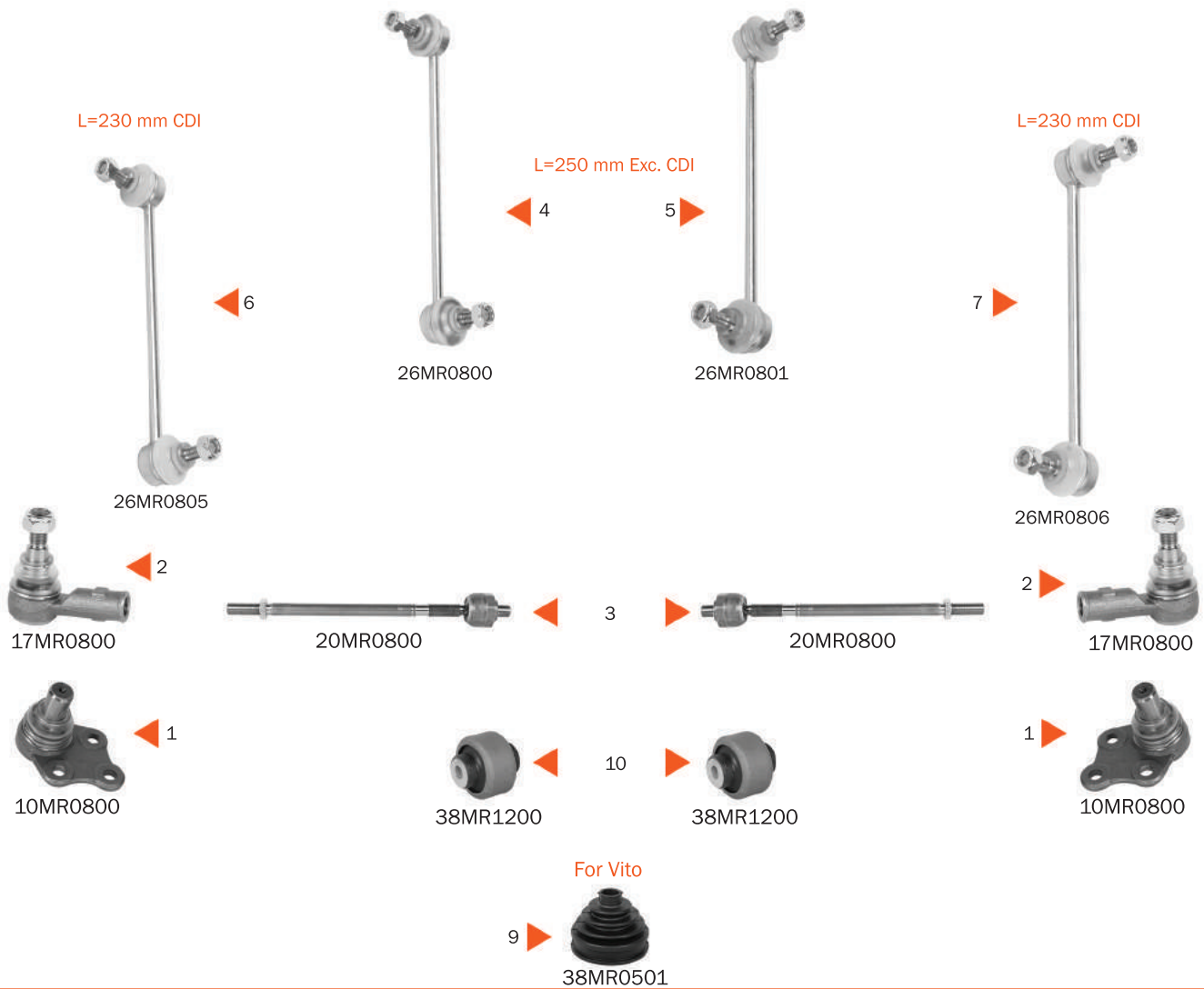

NO	ASMETAL CODE	DESCRIPTION	MEASURES	OEM
1	10MR0800	Ball Joint Lower	c:Ø22	638 330 00 27
2	17MR0800	Tie Rod End	c:Ø16,8 th:FM16x1,5 RHT	638 460 00 48
3	20MR0800	Axial Joint	th:MM16x1,5 RHT L:341,5mm	638 460 00 55
4	26MR0800	Stabiliser Link Left	L:250mm	638 323 02 68
5	26MR0801	Stabiliser Link Right	L:250mm	638 323 03 68
6	26MR0805	Stabiliser Link Left	L:230mm	638 323 04 68
7	26MR0806	Stabiliser Link Right	L:230mm	638 323 05 68
8	26MR0810	Stabiliser Link Rear	L:104,7mm	638 326 01 16
9	38MR0501	Axle Boot	di:Ø24	000 327 00 85
10	38MR1200	Silentblock for TCA	di:Ø14,1 do:Ø70,5	638 333 08 14

MERCEDES - BENZ

VITO

VITO (W639, V639)
VIANO (W639, V639)



09/2003 -->
09/2003 -->

-> 09/2010



26MR0816

6



26MR0815

5

-> 08/2010



38MR0130
-> CHAS 3 603471

7

-> 08/2010



7

38MR0130
-> CHAS 3 603471



17MR0816

3



20MR0815

4



20MR0815

2



17MR0815



10MR0815

1



10MR0815

1



45MR0600

8



45MR0600

8

NO	ASMETAL CODE	DESCRIPTION	MEASURES	OEM
1	10MR0815	Ball Joint Lower	c:Ø22	639 333 02 27
2	17MR0815	Tie Rod End Right	c:Ø17 th:FM16x1,5 RHT	639 460 07 48
3	17MR0816	Tie Rod End Left	c:Ø17 th:FM16x1,5 RHT	639 460 06 48
4	20MR0815	Axial Joint	th:MM16x1,5 RHT L:288mm	639 460 02 55
5	26MR0815	Stabiliser Link Right	L:280mm	639 320 05 89
6	26MR0816	Stabiliser Link Left	L:280mm	639 320 04 89
7	38MR0130	Silentblock for TCA	di:Ø16,2	639 323 01 20
8	45MR0600	Engine Mounting	h:134mm thi:74,7mm thi:64,5mm	639 242 00 13